



## Welding machines and accessories

A/V EN 1090

099-008788-EW501

Observe additional system documents!

29.01.2015

**Register now!**  
For your benefit  
**Jetzt Registrieren**  
und Profitieren!

[www.ewm-group.com](http://www.ewm-group.com)



# General instructions

## CAUTION



### Read the operating instructions!

The operating instructions provide an introduction to the safe use of the products.

- Read the operating instructions for all system components!
- Observe accident prevention regulations!
- Observe all local regulations!
- Confirm with a signature where appropriate.

## NOTE



**In the event of queries on installation, commissioning, operation or special conditions at the installation site, or on usage, please contact your sales partner or our customer service department on +49 2680 181-0.**

**A list of authorised sales partners can be found at [www.ewm-group.com](http://www.ewm-group.com).**

Liability relating to the operation of this equipment is restricted solely to the function of the equipment. No other form of liability, regardless of type, shall be accepted. This exclusion of liability shall be deemed accepted by the user on commissioning the equipment.

The manufacturer is unable to monitor whether or not these instructions or the conditions and methods are observed during installation, operation, usage and maintenance of the equipment.

An incorrectly performed installation can result in material damage and injure persons as a result. For this reason, we do not accept any responsibility or liability for losses, damages or costs arising from incorrect installation, improper operation or incorrect usage and maintenance or any actions connected to this in any way.

© EWM AG · Dr. Günter-Henle-Str. 8 · D-56271 Mündersbach, Germany

The copyright to this document remains the property of the manufacturer.

Reprinting, including extracts, only permitted with written approval.

The content of this document has been prepared and reviewed with all reasonable care. The information provided is subject to change, errors excepted.

# 1 Contents

<b>1</b>	<b>Contents</b> .....	<b>3</b>
<b>2</b>	<b>Safety instructions</b> .....	<b>4</b>
2.1	Notes on the use of these operating instructions .....	4
2.2	Explanation of icons.....	5
2.3	General .....	6
2.4	Transport.....	8
2.5	Scope of delivery .....	8
2.5.1	Ambient conditions .....	8
2.5.1.1	In operation .....	8
2.5.1.2	Transport and storage.....	8
<b>3</b>	<b>Intended use</b> .....	<b>9</b>
3.1	Use and operation solely with the following machines .....	9
3.2	Documents which also apply .....	10
3.2.1	Warranty.....	10
3.2.2	Declaration of Conformity.....	10
3.2.3	Service documents (spare parts and circuit diagrams).....	10
3.2.4	Calibration/Validation .....	10
<b>4</b>	<b>Machine description – quick overview</b> .....	<b>11</b>
4.1	Scope of delivery .....	11
4.2	Front view .....	12
4.3	Rear view .....	14
<b>5</b>	<b>Design and function</b> .....	<b>15</b>
5.1	General .....	15
5.2	Transport and installation .....	15
<b>6</b>	<b>Assembly</b> .....	<b>16</b>
6.1	Decompact machines .....	16
6.1.1	Legend.....	17
6.2	Compact machines .....	18
6.2.1	Legend.....	19
6.2.2	Dimensions.....	19
6.2.2.1	Mira 151, 221 , 251, 301 FKG.....	19
6.2.2.2	Saturn 301-351 FKG .....	20
6.2.2.3	Wega 401 FKG, -FKW .....	20
6.2.3	Preparations .....	21
6.2.4	Connection cable connection .....	23
6.2.4.1	Mira .....	23
6.2.4.2	Saturn / Wega .....	23
6.3	Final inspection.....	24
<b>7</b>	<b>Maintenance, care and disposal</b> .....	<b>25</b>
7.1	General .....	25
7.2	Maintenance work.....	25
7.3	Maintenance work, intervals .....	25
7.3.1	Monthly maintenance tasks.....	25
7.4	Disposing of equipment .....	25
7.4.1	Manufacturer's declaration to the end user .....	26
7.5	Meeting the requirements of RoHS .....	26
<b>8</b>	<b>Technical data</b> .....	<b>27</b>
8.1	A/V EN 1090 .....	27
<b>9</b>	<b>Accessories</b> .....	<b>28</b>
9.1	General accessories .....	28
<b>10</b>	<b>Circuit diagrams</b> .....	<b>29</b>
10.1	A/V EN 1090 .....	29
<b>11</b>	<b>Appendix A</b> .....	<b>30</b>
11.1	Overview of EWM branches .....	30

## 2 Safety instructions

### 2.1 Notes on the use of these operating instructions

#### **DANGER**

**Working or operating procedures which must be closely observed to prevent imminent serious and even fatal injuries.**

- Safety notes include the "DANGER" keyword in the heading with a general warning symbol.
- The hazard is also highlighted using a symbol on the edge of the page.

#### **WARNING**

**Working or operating procedures which must be closely observed to prevent serious and even fatal injuries.**

- Safety notes include the "WARNING" keyword in the heading with a general warning symbol.
- The hazard is also highlighted using a symbol in the page margin.

#### **CAUTION**

**Working or operating procedures which must be closely observed to prevent possible minor personal injury.**

- The safety information includes the "CAUTION" keyword in its heading with a general warning symbol.
- The risk is explained using a symbol on the edge of the page.

#### **CAUTION**

**Working and operating procedures which must be followed precisely to avoid damaging or destroying the product.**

- The safety information includes the "CAUTION" keyword in its heading without a general warning symbol.
- The hazard is explained using a symbol at the edge of the page.

#### **NOTE**















**Special technical points which users must observe.**

- Notes include the "NOTE" keyword in the heading without a general warning symbol.

Instructions and lists detailing step-by-step actions for given situations can be recognised via bullet points, e.g.:

- Insert the welding current lead socket into the relevant socket and lock.

## 2.2 Explanation of icons

Symbol	Description
	Correct
	Wrong
	Press
	Do not press
	Press and keep pressed
	Turn
	Switch
	Switch off machine
	Switch on machine
	ENTER (enter the menu)
	NAVIGATION (Navigating in the menu)
	EXIT (Exit the menu)
	Time display (example: wait 4s/press)
	Interruption in the menu display (other setting options possible)
	Tool not required/do not use
	Tool required/use

## 2.3 General

### DANGER



#### Electric shock!

**Welding machines use high voltages which can result in potentially fatal electric shocks and burns on contact. Even low voltages can cause you to get a shock and lead to accidents.**

- Do not touch any live parts in or on the machine!
- Connection cables and leads must be free of faults!
- Switching off alone is not sufficient!
- Place welding torch and stick electrode holder on an insulated surface!
- The unit should only be opened by specialist staff after the mains plug has been unplugged!
- Only wear dry protective clothing!
- Wait for 4 minutes until the capacitors have discharged!



#### Electromagnetic fields!

**The power source may cause electrical or electromagnetic fields to be produced which could affect the correct functioning of electronic equipment such as IT or CNC devices, telecommunication lines, power cables, signal lines and pacemakers.**

- Observe the maintenance instructions - See 7 Maintenance, care and disposal chapter!
- Unwind welding leads completely!
- Shield devices or equipment sensitive to radiation accordingly!
- The correct functioning of pacemakers may be affected (obtain advice from a doctor if necessary).



#### Validity of this document!

**This document describes an accessory and is only valid in combination with the operating instructions for the power source being used (welding machine)!**

- Read the operating instructions, in particular the safety instructions for the power source (welding machine)!

### WARNING



#### Risk of accidents if these safety instructions are not observed!

**Non-observance of these safety instructions is potentially fatal!**

- Carefully read the safety information in this manual!
- Observe the accident prevention regulations in your country.
- Inform persons in the working area that they must observe the regulations!



#### Fire hazard!

**Flames may arise as a result of the high temperatures, stray sparks, glowing-hot parts and hot slag produced during the welding process.**

**Stray welding currents can also result in flames forming!**

- Check for fire hazards in the working area!
- Do not carry any easily flammable objects such as matches or lighters.
- Keep appropriate fire extinguishing equipment to hand in the working area!
- Thoroughly remove any residue of flammable substances from the workpiece before starting welding.
- Only continue work on welded workpieces once they have cooled down.  
Do not allow to come into contact with flammable material!
- Connect welding leads correctly!

**⚠ WARNING****Risk of injury due to radiation or heat!****Arc radiation results in injury to skin and eyes.****Contact with hot workpieces and sparks results in burns.**

- Use welding shield or welding helmet with the appropriate safety level (depending on the application)!
- Wear dry protective clothing (e.g. welding shield, gloves, etc.) according to the relevant regulations in the country in question!
- Protect persons not involved in the work against arc beams and the risk of glare using safety curtains!

**Hazards due to improper usage!****Hazards may arise for persons, animals and material objects if the equipment is not used correctly. No liability is accepted for any damages arising from improper usage!**

- The equipment must only be used in line with proper usage and by trained or expert staff!
- Do not modify or convert the equipment improperly!

**⚠ CAUTION****Noise exposure!****Noise exceeding 70 dBA can cause permanent hearing damage!**

- Wear suitable ear protection!
- Persons located within the working area must wear suitable ear protection!

**CAUTION****Obligations of the operator!****The respective national directives and laws must be observed for operation of the machine!**

- National implementation of the framework directive (89/391/EWG), as well as the associated individual directives.
- In particular, directive (89/655/EWG), on the minimum regulations for safety and health protection when staff members use equipment during work.
- The regulations regarding work safety and accident prevention for the respective country.
- Setting up and operating the machine according to IEC 60974-9.
- Check at regular intervals that users are working in a safety-conscious way.
- Regular checks of the machine according to IEC 60974-4.

**Damage due to the use of non-genuine parts!****The manufacturer's warranty becomes void if non-genuine parts are used!**

- Only use system components and options (power sources, welding torches, electrode holders, remote controls, spare parts and replacement parts, etc.) from our range of products!
- Only insert and lock accessory components into the relevant connection socket when the machine is switched off.

**Trained personnel!****Commissioning is reserved for persons who have the relevant expertise of working with arc welding machines.**

## 2.4 Transport

### CAUTION



**Damage due to supply lines not being disconnected!**

During transport, supply lines which have not been disconnected (mains supply leads, control leads, etc.) may cause hazards such as connected equipment tipping over and injuring persons!

- Disconnect supply lines!

## 2.5 Scope of delivery

The delivery is checked and packaged carefully before dispatch, however it is not possible to exclude the possibility of damage during transit.

### Receiving inspection

- Check that the delivery is complete using the delivery note!

### In the event of damage to the packaging

- Check the delivery for damage (visual inspection)!

### In the event of complaints

If the delivery has been damaged during transport:

- Please contact the last haulier immediately!
- Keep the packaging (for possible checking by the haulier or for the return shipment).

### Packaging for returns

If possible, please use the original packaging and the original packaging material. If you have any queries on packaging and protection during transport, please contact your supplier.

### 2.5.1 Ambient conditions

#### CAUTION



**Equipment damage due to dirt accumulation!**

Unusually high quantities of dust, acid, corrosive gases or substances may damage the equipment.

- Avoid high volumes of smoke, vapour, oil vapour and grinding dust!
- Avoid ambient air containing salt (sea air)!

#### 2.5.1.1 In operation

##### Temperature range of the ambient air:

- -25 °C to +40 °C

##### Relative air humidity:

- Up to 50% at 40 °C
- Up to 90% at 20 °C

#### 2.5.1.2 Transport and storage

##### Storage in an enclosed space, temperature range of the ambient air:

- -30 °C to +70 °C

##### Relative air humidity

- Up to 90% at 20 °C



### 3 Intended use

#### **WARNING**

**Hazards due to improper usage!**

**Hazards may arise for persons, animals and material objects if the equipment is not used correctly. No liability is accepted for any damages arising from improper usage!**

- The equipment must only be used in line with proper usage and by trained or expert staff!
- Do not modify or convert the equipment improperly!

#### 3.1 Use and operation solely with the following machines

**Display unit for non-digital welding machines within the scope of EN 1090**

For retrofitting all welding machines without digital control.

For the Mira, Saturn and Wega welding machine series.

## 3.2 Documents which also apply

### 3.2.1 Warranty

#### NOTE



For more information refer to the "Warranty registration" brochure supplied and our information regarding warranty, maintenance and testing at [www.ewm-group.com](http://www.ewm-group.com)!

### 3.2.2 Declaration of Conformity



The designated machine conforms to EC Directives and standards in terms of its design and construction:

- EC Low Voltage Directive (2006/95/EC),
- EC EMC Directive (2004/108/EC),

This declaration shall become null and void in the event of unauthorised modifications, improperly conducted repairs, non-observance of the deadlines for the repetition test and / or non-permitted conversion work not specifically authorised by the manufacturer.

The original copy of the declaration of conformity is enclosed with the unit.

### 3.2.3 Service documents (spare parts and circuit diagrams)



#### DANGER



**Do not carry out any unauthorised repairs or modifications!**

**To avoid injury and equipment damage, the unit must only be repaired or modified by specialist, skilled persons!**

**The warranty becomes null and void in the event of unauthorised interference.**

- Appoint only skilled persons for repair work (trained service personnel)!

Spare parts can be obtained from the relevant authorised dealer.







### 3.2.4 Calibration/Validation

We hereby confirm that this machine has been tested using calibrated measuring equipment, as stipulated in IEC/EN 60974, ISO/EN 17662, EN 50504, and complies with the admissible tolerances.

Recommended calibration interval: 12 months

## 4 Machine description – quick overview

### 4.1 Scope of delivery

Position	Quantity	Type and designation	Item number
	1	<b>A/V EN 1090</b> Display unit for non-digital welding machines within the scope of EN 1090	090-008788-00000
	1	<b>CONCAB CAL 95QMM 4M</b> Calibration connection cable.	092-011860-00000
	1	<b>ML 2M RT ISO</b> Measuring line 2 M, red insulation.	094-019826-00000
	1	<b>H05V-K 1.5QMM 95MM RT</b> Mira calibration cable.	094-000005-00701
	1	<b>H05V-K 1.5QMM 340MM RT</b> Saturn/Wega calibration cable.	094-000005-00702
	1	<b>CAN-CBN REP</b> Connection socket.	094-008544-00000
	1	<b>VTS ADAP</b> Welding voltage test adapter.	098-005126-00000

## 4.2 Front view

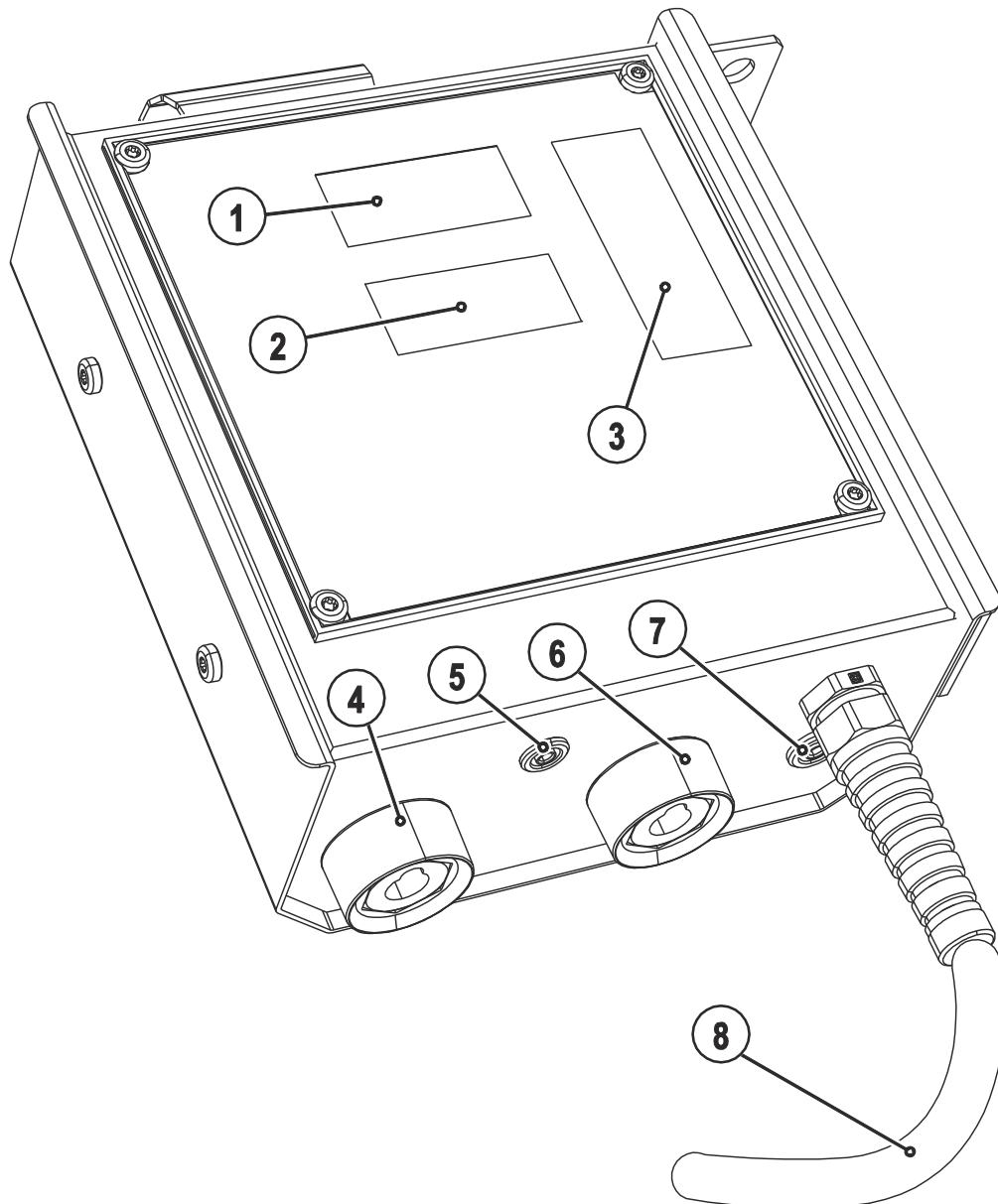



Figure 4-1

Item	Symbol	Description
1		<b>Digital welding current display</b>
2		<b>Digital welding voltage display</b>
3		<b>Adhesive film "Calibration"</b> Calibration date, tester, serial number, safety check date
4		<b>Welding current connection socket, input</b> Connection from welding machine, "-" current socket
5		<b>Connection socket for voltage measurement</b> Connection for the separate measuring lines to measure the voltage directly at the welding machine.
6		<b>Welding current connection socket, output</b> Connection to the workpiece
7	<b>F1</b>	<b>Machine fuse (6,3 AT)</b> Protection of accessory components mains connection sockets 16 A CEE 7/4
8		<b>Mains connection lead</b>

## 4.3 Rear view

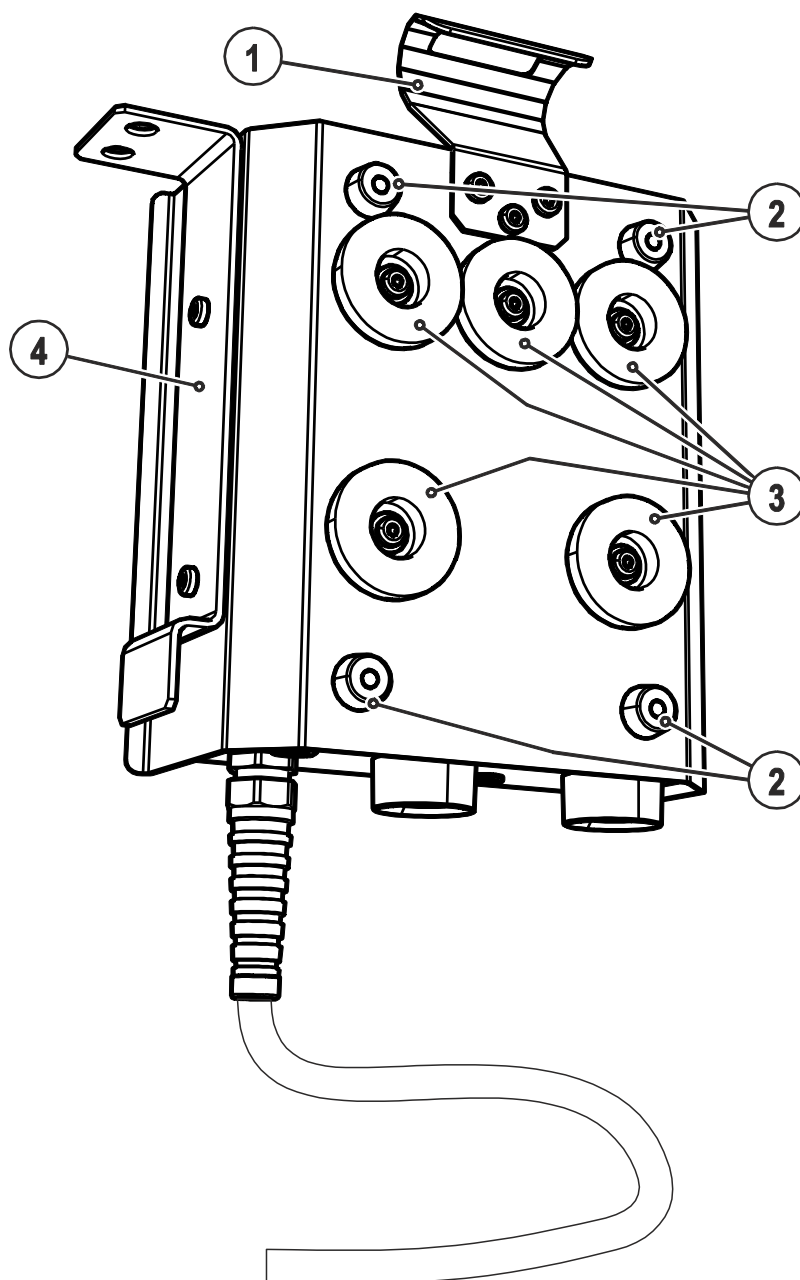

Figure 4-2

Item	Symbol	Description
1		<b>Holder for suspending the display unit</b>
2		<b>Machine feet</b>
3		<b>Fixing magnet</b> To mount remote control on magnetisable surfaces
4		<b>Support bracket</b> To attach the display unit to the lifting eyes of a power source.

## 5 Design and function

### 5.1 General

#### DANGER



**Do not carry out any unauthorised repairs or modifications!**

**To avoid injury and equipment damage, the unit must only be repaired or modified by specialist, skilled persons!**

**The warranty becomes null and void in the event of unauthorised interference.**

- Appoint only skilled persons for repair work (trained service personnel)!

#### WARNING



**Risk of injury from electric shock!**

**Contact with live parts, e.g. welding current sockets, is potentially fatal!**

- Follow safety instructions on the opening pages of the operating instructions.
- Commissioning may only be carried out by persons who have the relevant expertise of working with arc welding machines!
- Connection and welding leads (e.g. electrode holder, welding torch, workpiece lead, interfaces) may only be connected when the machine is switched off!



**Risk of accidents if these safety instructions are not observed!**

**Non-observance of these safety instructions is potentially fatal!**

- Carefully read the safety information in this manual!
- Observe the accident prevention regulations in your country.
- Inform persons in the working area that they must observe the regulations!

#### NOTE



**Observe documentation of other system components when connecting!**

### 5.2 Transport and installation

#### CAUTION



**Installation site!**

**The machine must not be operated in the open air and must only be set up and operated on a suitable, stable and level base!**

- The operator must ensure that the ground is non-slip and level, and provide sufficient lighting for the place of work.
- Safe operation of the machine must be guaranteed at all times.

## 6 Assembly

### 6.1 Decompact machines

#### NOTE

 The illustration serves as an example only.

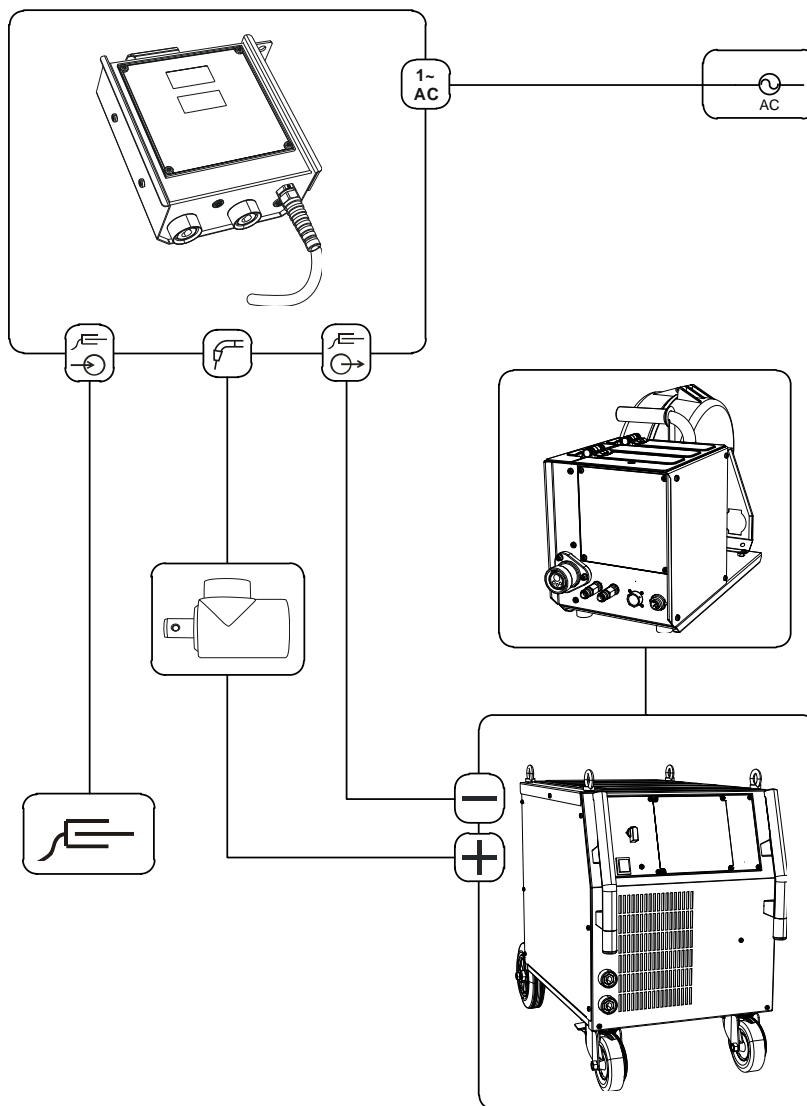









Figure 6-1



**6.1.1 Legend**

	Welding current (minus potential)
	Welding current (plus potential)
	Welding voltage connection
	Welding current connection, output
	Welding current connection, input
	Current adapter (T piece) with connection socket
	Supply voltage connection (1-phase)

## 6.2 Compact machines

### ⚠ CAUTION



#### Mechanical conversion!

Observe all safety precautions and accident prevention regulations when undertaking machine conversion work, in order to prevent injuries.

- Observe the safety precautions given in the standard operating instructions.
- Observe accident prevention regulations!

### CAUTION



To perform the following steps, the protective flap of the wire feeder needs to be opened. Make sure to close the protective flap again before starting to work.

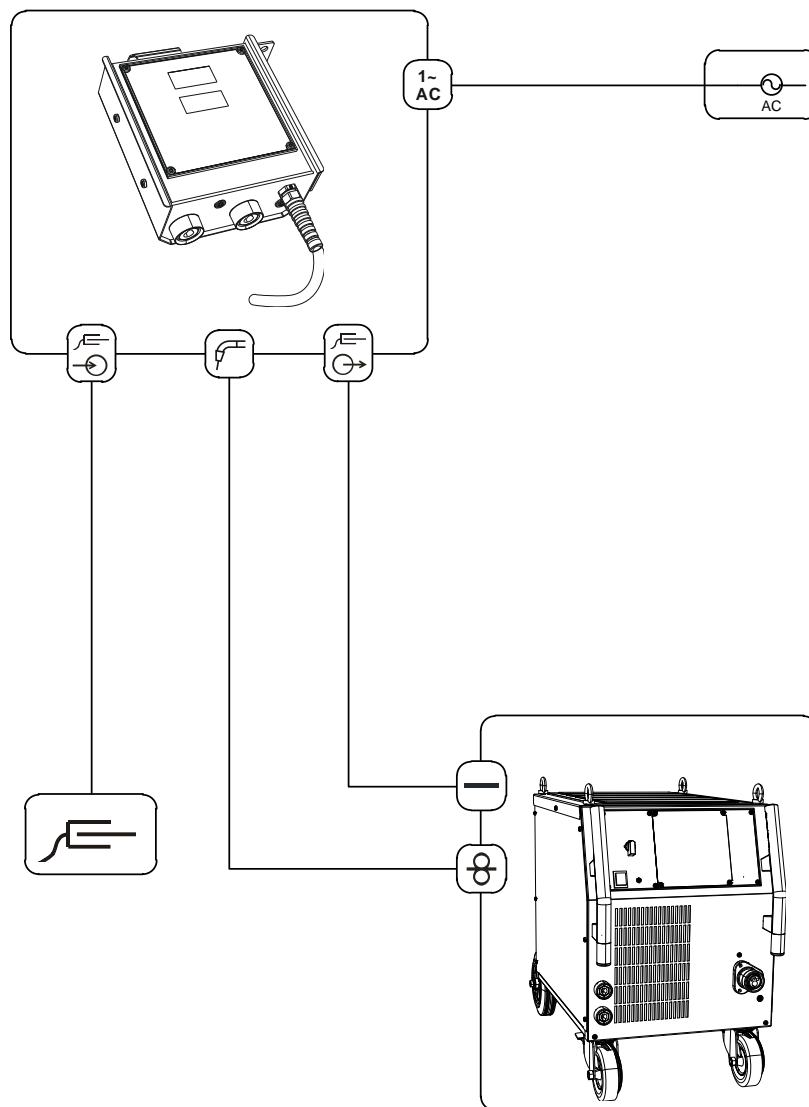

Figure 6-2

### 6.2.1 Legend

	Welding current (minus potential)
	Welding voltage connection
	Welding current connection, power source
	Welding current connection, output
	Welding current connection, input
	Supply voltage connection (1-phase)

### 6.2.2 Dimensions

#### 6.2.2.1 Mira 151, 221, 251, 301 FKG

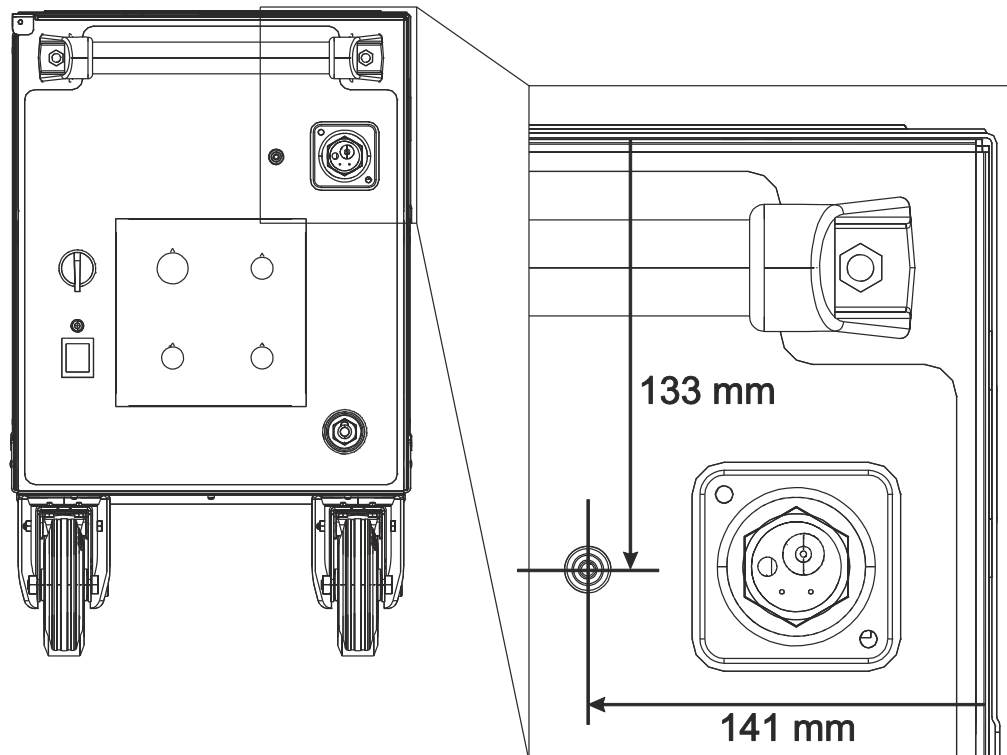

Figure 6-3

**6.2.2.2 Saturn 301-351 FKG**

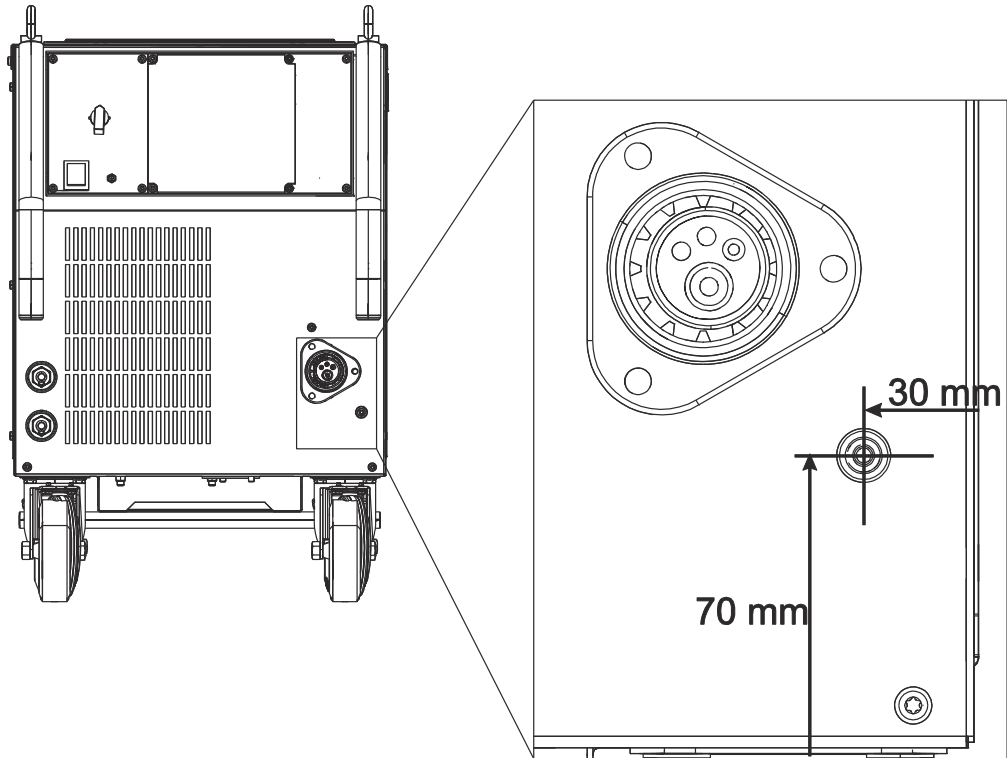

Figure 6-4

**6.2.2.3 Wega 401 FKG, -FKW**

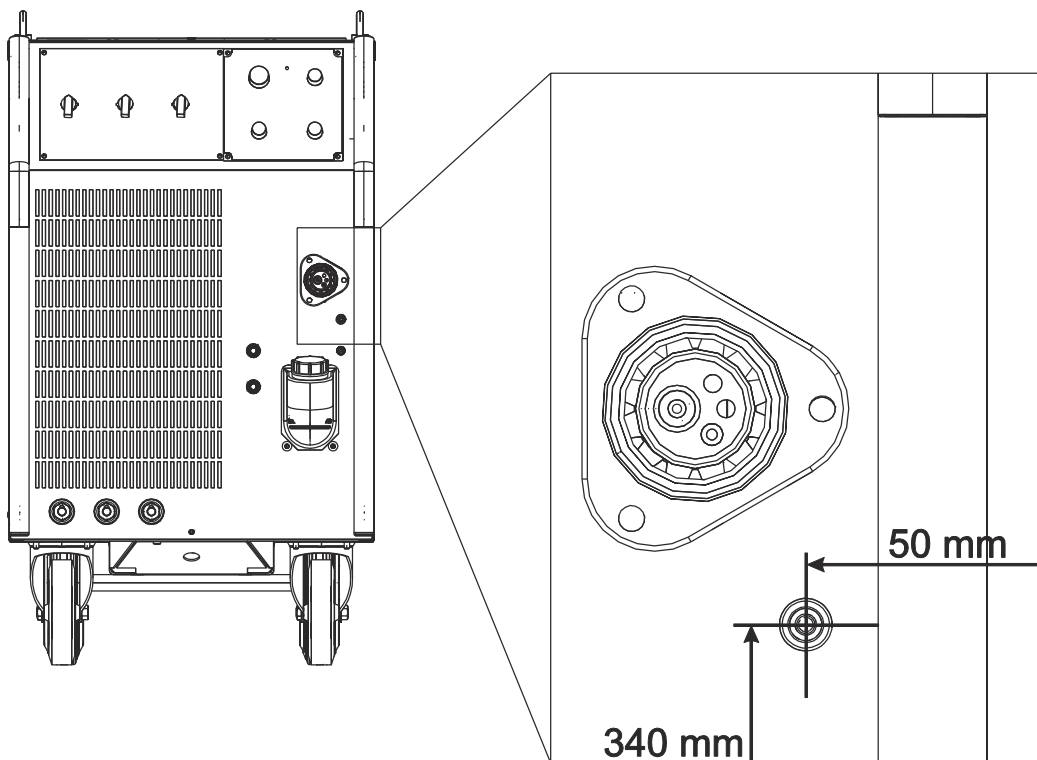

Figure 6-5

## 6.2.3 Preparations

a)  $\varnothing$  4 mmb)  $\varnothing$  12 mm

Figure 6-6

Item	Symbol	Description
1		Power source
2		Bore

- Mark the bore centre according to the power source.
- Pre-drill a hole with a diameter of 4 mm.
- Drill again to enlarge the bore to a diameter of 12 mm.
- Burr the bore.

**NOTE**

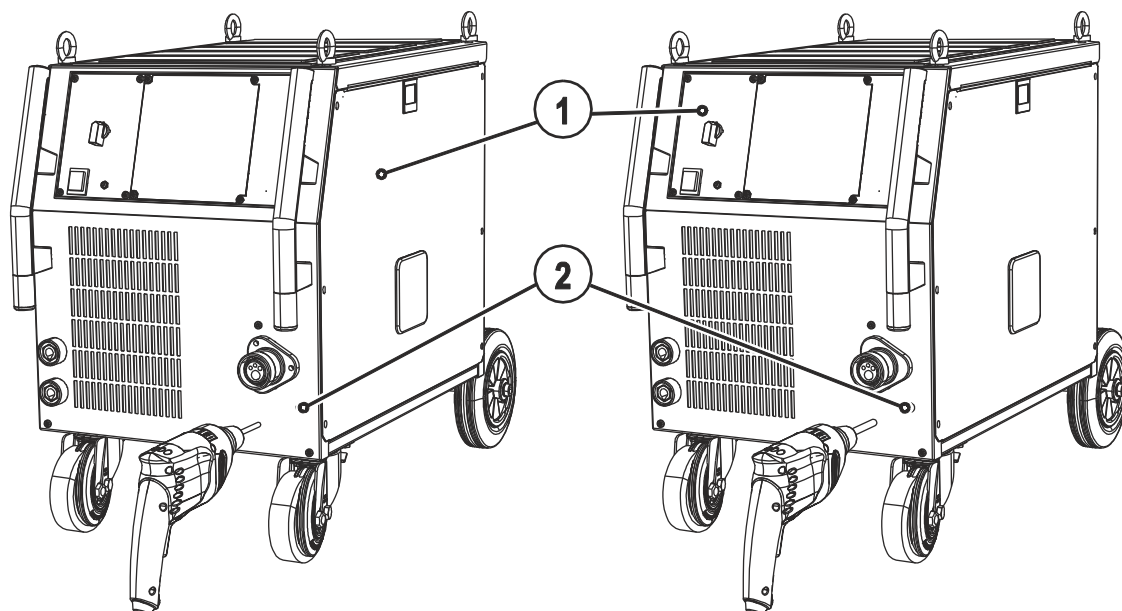
The illustration serves as an example only.

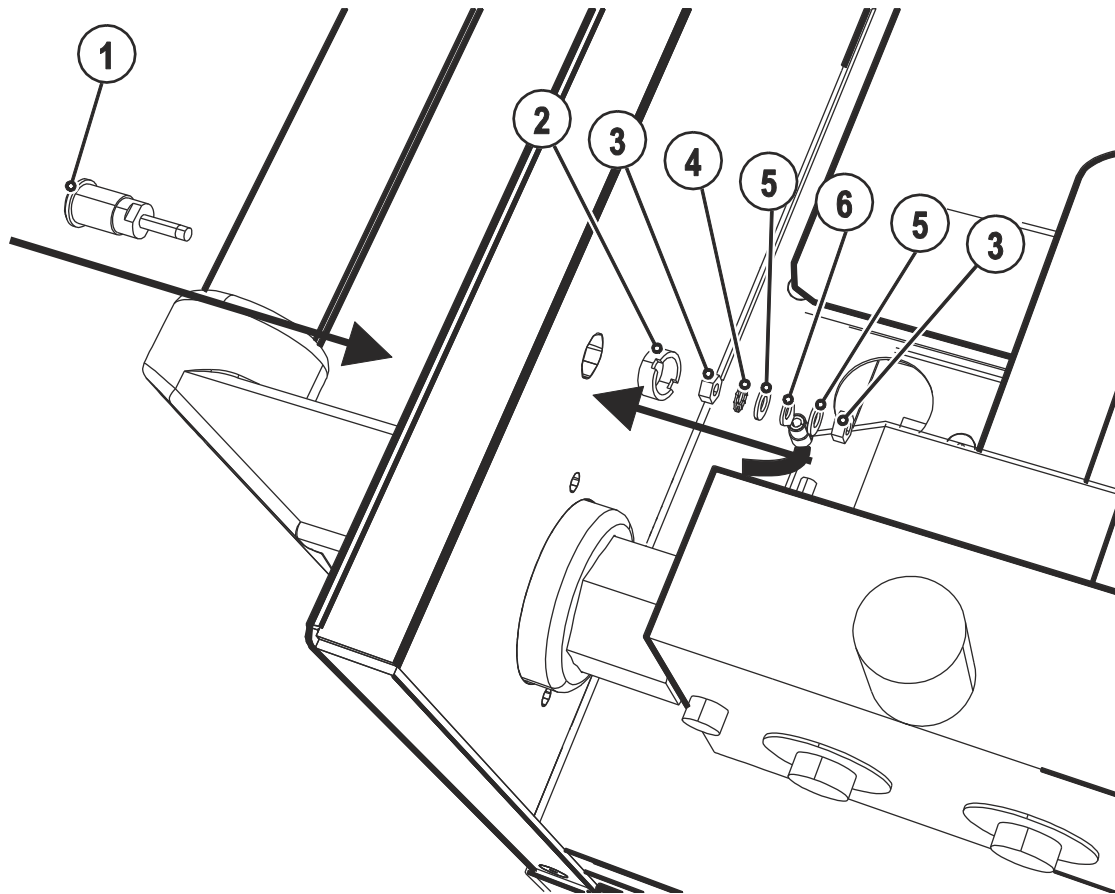

Figure 6-7

Item	Symbol	Description
1		Connection socket
2		Crown nut
3		Hexagon nut
4		Fan-type lock washer
5		Plain washer
6		Connection lead

- Install connection socket as shown.

## 6.2.4 Connection cable connection

### 6.2.4.1 Mira

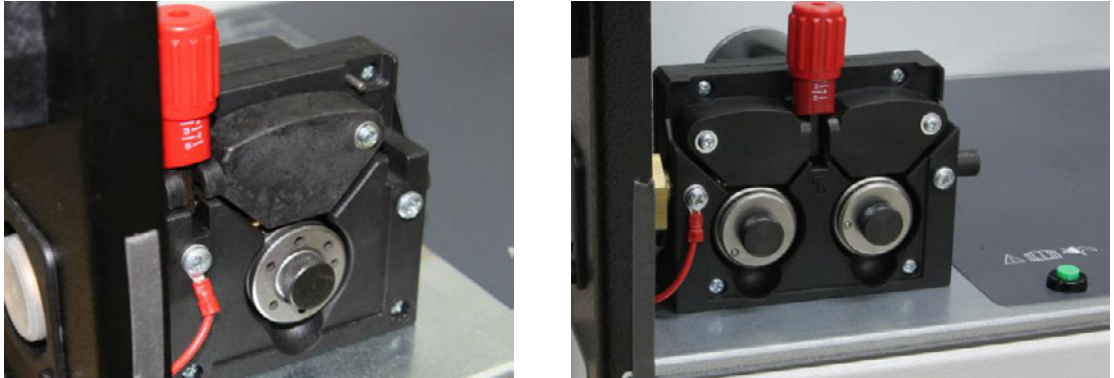

Figure 6-8

### 6.2.4.2 Saturn / Wega

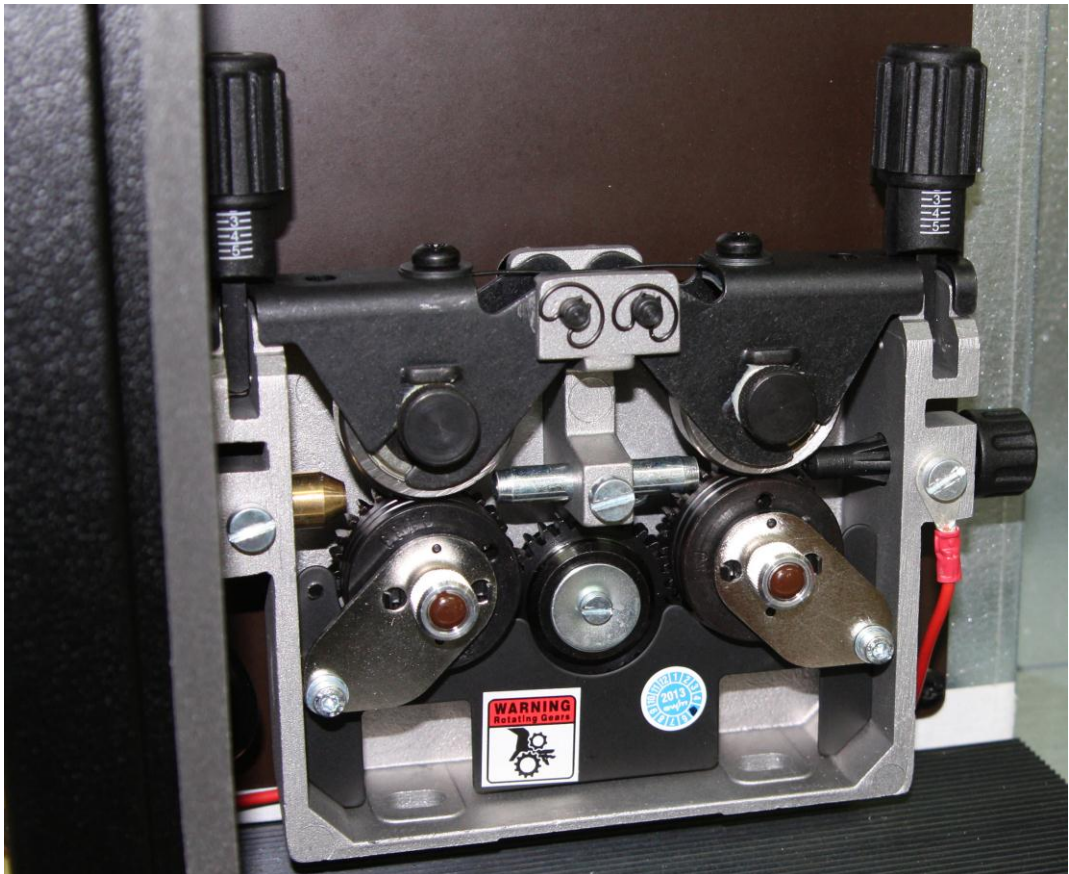

Figure 6-9

## 6.3 Final inspection

### **WARNING**



**Danger due to failure to carry out the final inspection!**

**After installation or conversion, all mechanical and electrical connections must be checked for correct installation to avoid any potential injuries.**

- No leads or tubes should be squashed or laid on sharp edges.
- Check all mechanical connections to ensure that they are fitted correctly!
- Carry out the final inspection!
- Carry out the functional test!

### **CAUTION**



**Test!**

**Before re-commissioning, it is essential that an "inspection and test during operation" is carried out conforming to IEC / DIN EN 60974-4 "Arc welding devices - inspection and testing during operation"!**

- For detailed instructions, please see the standard operating instructions for the welding machine.

### **NOTE**



- **Keep the conversion instructions with the machine documentation!**
- **When ordering spare parts, ensure that the item number and serial number of the machine are quoted!**



## 7 Maintenance, care and disposal

### 7.1 General

When used in the specified environmental conditions and under normal operating conditions, this machine is largely maintenance-free and requires a minimum of care.

There are some points, which should be observed, to guarantee fault-free operation of your welding machine. Among these are regular cleaning and checking as described below, depending on the pollution level of the environment and the length of time the unit is in use.

### 7.2 Maintenance work

#### DANGER



**Do not carry out any unauthorised repairs or modifications!**

**To avoid injury and equipment damage, the unit must only be repaired or modified by specialist, skilled persons!**

**The warranty becomes null and void in the event of unauthorised interference.**

- Appoint only skilled persons for repair work (trained service personnel)!

Repair and maintenance work may only be performed by qualified authorised personnel; otherwise the right to claim under warranty is void. In all service matters, always consult the dealer who supplied the machine. Return deliveries of defective equipment subject to warranty may only be made through your dealer. When replacing parts, use only original spare parts. When ordering spare parts, please quote the machine type, serial number and item number of the machine, as well as the type designation and item number of the spare part.

### 7.3 Maintenance work, intervals

#### 7.3.1 Monthly maintenance tasks

- Check control leads and their strain relief for damage.
- Carry out functional test of operating, signalling, safety and/or adjustment devices.
- Other, general condition

### 7.4 Disposing of equipment

#### NOTE



**Proper disposal!**

**The machine contains valuable raw materials, which should be recycled, and electronic components, which must be disposed of.**

- Do not dispose of in household waste!
- Observe the local regulations regarding disposal!



## 7.4.1 Manufacturer's declaration to the end user

- According to European provisions (guideline 2002/96/EG of the European Parliament and the Council of January, 27th 2003), used electric and electronic equipment may no longer be placed in unsorted municipal waste. It must be collected separately. The symbol depicting a waste container on wheels indicates that the equipment must be collected separately.  
This machine is to be placed for disposal or recycling in the waste separation systems provided for this purpose.
- According to German law (law governing the distribution, taking back and environmentally correct disposal of electric and electronic equipment (ElektroG) from 16.03.2005), used machines are to be placed in a collection system separate from unsorted municipal waste. The public waste management utilities (communities) have created collection points at which used equipment from private households can be disposed of free of charge.
- Information about giving back used equipment or about collections can be obtained from the respective municipal administration office.
- EWM participates in an approved waste disposal and recycling system and is registered in the Used Electrical Equipment Register (EAR) under number WEEE DE 57686922.
- In addition to this, returns are also possible throughout Europe via EWM sales partners.

## 7.5 Meeting the requirements of RoHS

We, EWM AG Mündersbach, hereby confirm that all products supplied by us which are affected by the RoHS Directive, meet the requirements of the RoHS (Directive 2011/65/EU).

## 8 Technical data

### NOTE



Performance specifications and guarantee only in connection with original spare and replacement parts!

### 8.1 A/V EN 1090

Mains voltage	1 x 230 V (-25% to +20%)
Mains fuse (safety fuse, slow-blow)	1 x 16 A
Machine fuse	630 mA
Max. current/duty cycle	600 A/60% DC 450 A/100% DC
Voltage range	0–100 V
Measuring accuracy	+/- 2.5%
Protection classification	IP 23
Dimensions L x W x H	390 x 270 x 110 mm
Weight	5 kg
EMC class	A
Constructed to standard	IEC 60974-1, -10 S / C €

## 9 Accessories

### NOTE



Performance-dependent accessories like torches, workpiece leads, electrode holders or intermediate hose packages are available from your authorised dealer.

### 9.1 General accessories

Type	Designation	Item no.
0,63A/6,3X32MM/250V/TRÄG E	Fuse	094-005482-00000
KLF CAL 2013-2018	CALIBRATION ADHESIVE FILM YEAR2013-2018	094-002471-00503
CONCAB CAL 95QMM 4M	Calibration connection cable	092-011860-00000
ML 2M RT ISO	Measuring line 2 M, red insulation.	094-019826-00000
VTS ADAP	Welding voltage test adapter	098-005126-00000

# 10 Circuit diagrams

## 10.1 A/V EN 1090

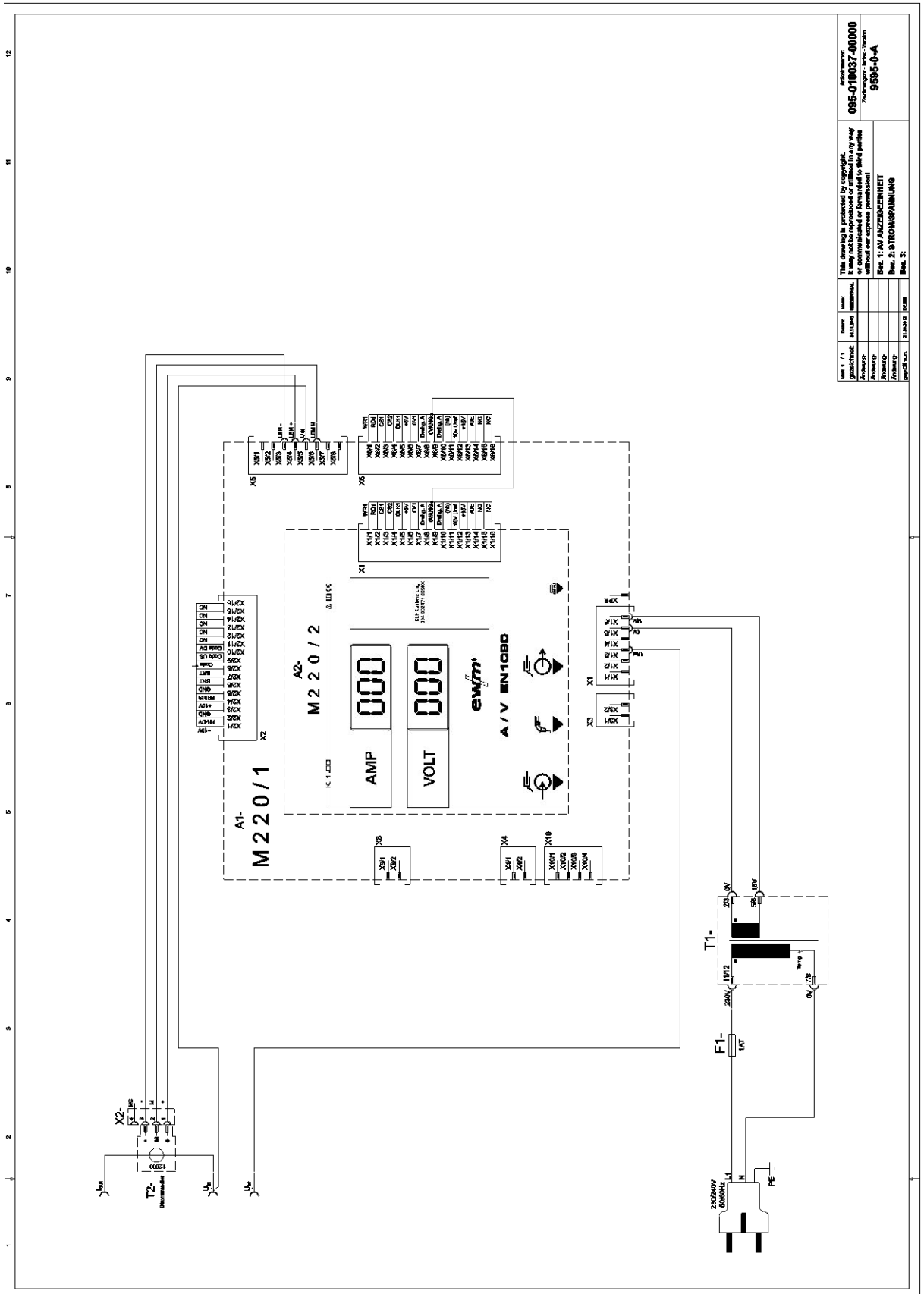

Blatt 1 / 1	Blatt:	This drawing is protected by copyright. Any use not authorized by EWM is prohibited or forbidden to third parties without our express permission!	Approval-Code:
Produktcode	A11320		095-010037-00000
Articelcode			Zonering: see: 1090
Revisiecode			9399-0-A
Revisie			Blat. 1: A/V ANZEIGENHEIT
			Blat. 2: STROMSPANNUNG
Blattcode	A11320/1		Blat. 5:

Figure 10-1

## 11 Appendix A

### 11.1 Overview of EWM branches

#### Headquarters

##### EWM AG

Dr. Günter-Henle-Straße 8  
56271 Mündersbach · Germany  
Tel: +49 2680 181-0 · Fax: -244  
www.ewm-group.com · info@ewm-group.com

#### Technology centre

##### EWM AG

Forststraße 7-13  
56271 Mündersbach · Germany  
Tel: +49 2680 181-0 · Fax: -144  
www.ewm-group.com · info@ewm-group.com



#### Production, Sales and Service

##### EWM AG

Dr. Günter-Henle-Straße 8  
56271 Mündersbach · Germany  
Tel: +49 2680 181-0 · Fax: -244  
www.ewm-group.com · info@ewm-group.com

##### EWM HIGH TECHNOLOGY (Kunshan) Ltd.

10 Yuanshan Road, Kunshan · New & Hi-tech Industry Development Zone  
Kunshan City · Jiangsu · Post code 215300 · People's Republic of China  
Tel: +86 512 57867-188 · Fax: -182  
www.ewm.cn · info@ewm.cn · info@ewm-group.cn

##### TEAMWELDER s.r.o.

Tř. 9. května 718 / 31  
407 53 Jířkovic · Czech Republic  
Tel.: +420 412 358-551 · Fax: -504  
www.teamwelder.cz · info@teamwelder.cz

#### Sales and Service Germany

##### EWM AG

Sales and Logistics Centre  
Sälzerstraße 20a  
56235 Ransbach-Baumbach · Tel: +49 2623 9276-0 · Fax: -244  
www.ewm-ransbach-baumbach.de · info@ewm-ransbach-baumbach.de

##### EWM AG

Sales and Technology Centre  
Grünauer Fenn 4  
14712 Rathenow · Tel: +49 3385 49402-0 · Fax: -20  
www.ewm-rathenow.de · info@ewm-rathenow.de

##### EWM AG

Rudolf-Winkel-Straße 7-9  
37079 Göttingen · Tel: +49 551-3070713-0 · Fax: -20  
www.ewm-goettingen.de · info@ewm-goettingen.de

##### EWM AG

Sachsstraße 28  
50259 Pulheim · Tel: +49 2234 697-047 · Fax: -048  
www.ewm-pulheim.de · info@ewm-pulheim.de

##### EWM AG

Eiserfelder Straße 300  
57080 Siegen · Tel: +49 271 3878103-0 · Fax: -9  
www.ewm-siegen.de · info@ewm-siegen.de

##### EWM HIGHTEC WELDING GmbH

Sales and Technology Centre  
Draisstraße 2a  
69469 Weinheim · Tel: +49 6201 84557-0 · Fax: -20  
www.ewm-weinheim.de · info@ewm-weinheim.de

##### EWM Schweißtechnik Handels GmbH

Karlsdorfer Straße 43  
88069 Tettngang · Tel: +49 7542 97998-0 · Fax: -29  
www.ewm-tettngang.de · info@ewm-tettngang.de

##### EWM Schweißtechnik Handels GmbH

Pfaffensteig 17  
89143 Blaubeuren · Tel: +49 7344 9191-75 · Fax: -77  
www.ewm-blaubeuren.de · info@ewm-blaubeuren.de

##### EWM Schweißtechnik Handels GmbH

Heinkelstraße 8  
89231 Neu-Ulm · Tel: +49 731 7047939-0 · Fax: -15  
www.ewm-neu-ulm.de · info@ewm-neu-ulm.de

#### Sales and Service International

##### EWM HIGHTEC WELDING GmbH

Wiesenstraße 27b  
4812 Pinsdorf · Austria · Tel: +43 7612 778 02-0 · Fax: -20  
www.ewm-austria.at · info@ewm-austria.at

##### EWM HIGH TECHNOLOGY (Kunshan) Ltd.

10 Yuanshan Road, Kunshan · New & Hi-tech Industry Development Zone  
Kunshan City · Jiangsu · Post code 215300 · People's Republic of China  
Tel: +86 512 57867-188 · Fax: -182  
www.ewm.cn · info@ewm.cn · info@ewm-group.cn

##### EWM HIGHTEC WELDING UK Ltd.

Unit 2B Coopies Way · Coopies Lane Industrial Estate  
Morpeth · Northumberland · NE61 6JN · Great Britain  
Tel: +44 1670 505875 · Fax: -514305  
www.ewm-morpeth.co.uk · info@ewm-morpeth.co.uk

##### EWM HIGHTEC WELDING Sales s.r.o. / Prodejní a poradenské centrum

Tyršova 2106  
256 01 Benešov u Prahy · Czech Republic  
Tel: +420 317 729-517 · Fax: -712  
www.ewm-benesov.cz · info@ewm-benesov.cz

