



Voltage divider
voltConverter 230/400

099-008800-EW501

Observe additional system documents!

17.09.2015

**Register now
and benefit!
Jetzt Registrieren
und Profitieren!**

www.ewm-group.com



General instructions

CAUTION



Read the operating instructions!

The operating instructions provide an introduction to the safe use of the products.

- Read the operating instructions for all system components!
- Observe accident prevention regulations!
- Observe all local regulations!
- Confirm with a signature where appropriate.



In the event of queries on installation, commissioning, operation or special conditions at the installation site, or on usage, please contact your sales partner or our customer service department on +49 2680 181-0.

A list of authorised sales partners can be found at www.ewm-group.com.

Liability relating to the operation of this equipment is restricted solely to the function of the equipment. No other form of liability, regardless of type, shall be accepted. This exclusion of liability shall be deemed accepted by the user on commissioning the equipment.

The manufacturer is unable to monitor whether or not these instructions or the conditions and methods are observed during installation, operation, usage and maintenance of the equipment. An incorrectly performed installation can result in material damage and injure persons as a result. For this reason, we do not accept any responsibility or liability for losses, damages or costs arising from incorrect installation, improper operation or incorrect usage and maintenance or any actions connected to this in any way.

© EWM AG · Dr. Günter-Henle-Str. 8 · D-56271 Mündersbach, Germany

The copyright to this document remains the property of the manufacturer.

Reprinting, including extracts, only permitted with written approval.

The content of this document has been prepared and reviewed with all reasonable care. The information provided is subject to change, errors excepted.

1 Contents

1	Contents	3
2	Safety instructions	4
2.1	Notes on the use of these operating instructions	4
2.2	Explanation of icons.....	5
2.3	General	6
2.4	Transport and installation	9
2.4.1	Ambient conditions	10
2.4.1.1	In operation	10
2.4.1.2	Transport and storage.....	10
3	Intended use	11
3.1	Applications.....	11
3.1.1	For operation only with the following equipment	11
3.2	Documents which also apply	12
3.2.1	Warranty	12
3.2.2	Declaration of Conformity.....	12
3.2.3	Welding in environments with increased electrical hazards.....	12
3.2.4	Service documents (spare parts and circuit diagrams).....	12
3.2.5	Calibration/Validation.....	12
4	Machine description – quick overview	13
4.1	Front view	13
4.2	Rear view	14
5	Design and function	15
5.1	General	15
5.2	Machine cooling.....	15
5.3	Transport and installation	15
5.4	Assembly/disassembly.....	16
5.4.1	Power source connection	18
5.5	Mains connection.....	19
5.5.1	Mains configuration	19
6	Maintenance, care and disposal	20
6.1	General	20
6.2	Maintenance work, intervals	20
6.2.1	Daily maintenance tasks.....	20
6.2.1.1	Visual inspection	20
6.2.1.2	Functional test.....	20
6.2.2	Monthly maintenance tasks.....	20
6.2.2.1	Visual inspection	20
6.2.3	Annual test (inspection and testing during operation)	20
6.3	Disposing of equipment	21
6.3.1	Manufacturer's declaration to the end user	21
6.4	Meeting the requirements of RoHS	21
7	Rectifying faults	22
7.1	Checklist for rectifying faults	22
8	Technical data	23
8.1	voltConverter 230/400.....	23
9	Accessories	24
9.1	Transport systems	24
10	Appendix A	25
10.1	Overview of EWM branches	25

2 Safety instructions

2.1 Notes on the use of these operating instructions

DANGER

Working or operating procedures which must be closely observed to prevent imminent serious and even fatal injuries.

- Safety notes include the "DANGER" keyword in the heading with a general warning symbol.
- The hazard is also highlighted using a symbol on the edge of the page.

WARNING

Working or operating procedures which must be closely observed to prevent serious and even fatal injuries.

- Safety notes include the "WARNING" keyword in the heading with a general warning symbol.
- The hazard is also highlighted using a symbol in the page margin.

CAUTION

Working or operating procedures which must be closely observed to prevent possible minor personal injury.

- The safety information includes the "CAUTION" keyword in its heading with a general warning symbol.
- The risk is explained using a symbol on the edge of the page.

CAUTION

Working and operating procedures which must be followed precisely to avoid damaging or destroying the product.

















- The safety information includes the "CAUTION" keyword in its heading without a general warning symbol.
- The hazard is explained using a symbol at the edge of the page.

Special technical points which users must observe.

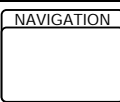
Instructions and lists detailing step-by-step actions for given situations can be recognised via bullet points, e.g.:

- Insert the welding current lead socket into the relevant socket and lock.

2.2 Explanation of icons

Symbol	Description
	Special technical points which users must observe.
	Correct
	Wrong
	Press
	Do not press
	Press and keep pressed
	Turn
	Switch
	Switch off machine
	Switch on machine
	ENTER (enter the menu)
	NAVIGATION (Navigating in the menu)
	EXIT (Exit the menu)
	Time display (example: wait 4s/press)
	Interruption in the menu display (other setting options possible)
	Tool not required/do not use
	Tool required/use

2.3 General

DANGER



Do not carry out any unauthorised repairs or modifications!

To avoid injury and equipment damage, the unit must only be repaired or modified by specialist, skilled persons!

The warranty becomes null and void in the event of unauthorised interference.

- Appoint only skilled persons for repair work (trained service personnel)!

WARNING



Validity of this document!

This document is only valid in combination with the operating instructions for the power source being used (welding machine)!

- Read the operating instructions, in particular the safety instructions for the power source (welding machine)!



Risk of accidents if these safety instructions are not observed!

Non-observance of these safety instructions is potentially fatal!

- Carefully read the safety information in this manual!
- Observe the accident prevention regulations in your country.
- Inform persons in the working area that they must observe the regulations!



Hazards due to improper usage!

Hazards may arise for persons, animals and material objects if the equipment is not used correctly. No liability is accepted for any damages arising from improper usage!

- The equipment must only be used in line with proper usage and by trained or expert staff!
- Do not modify or convert the equipment improperly!

CAUTION**Obligations of the operator!****The respective national directives and laws must be observed for operation of the machine!**

- National implementation of the framework directive (89/391/EWG), as well as the associated individual directives.
- In particular, directive (89/655/EWG), on the minimum regulations for safety and health protection when staff members use equipment during work.
- The regulations regarding work safety and accident prevention for the respective country.
- Setting up and operating the machine according to IEC 60974-9.
- Check at regular intervals that users are working in a safety-conscious way.
- Regular checks of the machine according to IEC 60974-4.

**Damage due to the use of non-genuine parts!****The manufacturer's warranty becomes void if non-genuine parts are used!**

- Only use system components and options (power sources, welding torches, electrode holders, remote controls, spare parts and replacement parts, etc.) from our range of products!
- Only insert and lock accessory components into the relevant connection socket when the machine is switched off.

**Damage to the machine due to stray welding currents!****Stray welding currents can destroy protective earth conductors, damage equipment and electronic devices and cause overheating of components leading to fire.**

- Make sure all welding leads are securely connected and check regularly.
- Always ensure a proper and secure electrical connection to the workpiece!
- Set up, attach or suspend all conductive power source components like casing, transport vehicle and crane frames so they are insulated!
- Do not place any other electronic devices such as drillers or angle grinders, etc., on the power source, transport vehicle or crane frames unless they are insulated!
- Always put welding torches and electrode holders on an insulated surface when they are not in use!

**Mains connection****Requirements for connection to the public mains network**

High-performance machines can influence the mains quality by taking current from the mains network. For some types of machines, connection restrictions or requirements relating to the maximum possible line impedance or the necessary minimum supply capacity at the interface with the public network (Point of Common Coupling, PCC) can therefore apply. In this respect, attention is also drawn to the machines' technical data. In this case, it is the responsibility of the operator, where necessary in consultation with the mains network operator, to ensure that the machine can be connected.

CAUTION



EMC Machine Classification

In accordance with IEC 60974-10, welding machines are grouped in two electromagnetic compatibility classes - See 8 Technical data chapter:

Class A machines are not intended for use in residential areas where the power supply comes from the low-voltage public mains network. When ensuring the electromagnetic compatibility of class A machines, difficulties can arise in these areas due to interference not only in the supply lines but also in the form of radiated interference.

Class B machines fulfil the EMC requirements in industrial as well as residential areas, including residential areas connected to the low-voltage public mains network.

Setting up and operating

When operating arc welding systems, in some cases, electro-magnetic interference can occur although all of the welding machines comply with the emission limits specified in the standard. The user is responsible for any interference caused by welding.

In order to **evaluate** any possible problems with electromagnetic compatibility in the surrounding area, the user must consider the following: (see also EN 60974-10 Appendix A)

- Mains, control, signal and telecommunication lines
- Radios and televisions
- Computers and other control systems
- Safety equipment
- The health of neighbouring persons, especially if they have a pacemaker or wear a hearing aid
- Calibration and measuring equipment
- The immunity to interference of other equipment in the surrounding area
- The time of day at which the welding work must be carried out

Recommendations for **reducing interference emission**

- Mains connection, e.g. additional mains filter or shielding with a metal tube
- Maintenance of the arc welding equipment
- Welding leads should be as short as possible and run closely together along the ground
- Potential equalization
- Earthing of the workpiece. In cases where it is not possible to earth the workpiece directly, it should be connected by means of suitable capacitors.
- Shielding from other equipment in the surrounding area or the entire welding system

2.4 Transport and installation

WARNING



Risk of accident due to improper transport of machines that may not be lifted!

Do not lift or suspend the machine! The machine can fall down and cause injuries! The handles and brackets are suitable for transport by hand only!

- The machine may not be lifted by crane or suspended!

CAUTION



Risk of tipping!

There is a risk of the machine tipping over and injuring persons or being damaged itself during movement and set up. Tilt resistance is guaranteed up to an angle of 10° (according to EN 60974-A2).

- Set up and transport the machine on level, solid ground!
- Secure add-on parts using suitable equipment!
- Replace damaged wheels and their fixing elements!
- Fix external wire feed units during transport (avoid uncontrolled rotation)!



Damage due to supply lines not being disconnected!

During transport, supply lines which have not been disconnected (mains supply leads, control leads, etc.) may cause hazards such as connected equipment tipping over and injuring persons!

- Disconnect supply lines!

CAUTION



Equipment damage when not operated in an upright position!

The units are designed for operation in an upright position!

Operation in non-permissible positions can cause equipment damage.

- Only transport and operate in an upright position!

2.4.1 Ambient conditions

CAUTION



Equipment damage due to dirt accumulation!

Unusually high quantities of dust, acid, corrosive gases or substances may damage the equipment.

- Avoid high volumes of smoke, vapour, oil vapour and grinding dust!
- Avoid ambient air containing salt (sea air)!



Non-permissible ambient conditions!

Insufficient ventilation results in a reduction in performance and equipment damage.

- Observe the ambient conditions!
- Keep the cooling air inlet and outlet clear!
- Observe the minimum distance of 0.5 m from obstacles!

2.4.1.1 In operation

Temperature range of the ambient air:

- -25 °C to +40 °C

Relative air humidity:

- Up to 50% at 40 °C
- Up to 90% at 20 °C

2.4.1.2 Transport and storage

Storage in an enclosed space, temperature range of the ambient air:

- -30 °C to +70 °C

Relative air humidity

- Up to 90% at 20 °C

3 Intended use

WARNING



Hazards due to improper usage!

Hazards may arise for persons, animals and material objects if the equipment is not used correctly. No liability is accepted for any damages arising from improper usage!

- The equipment must only be used in line with proper usage and by trained or expert staff!
- Do not modify or convert the equipment improperly!

3.1 Applications

To operate welding machines with a mains voltage of 400 V in a 3 x 230 V network.

3.1.1 For operation only with the following equipment

Power source

- Phoenix 355, 405, 505 TDM
- Phoenix 355 TKM
- Taurus 355, 405, 505 TDM
- Taurus 355 TKM
- Picomig 185, 305 D3 TKG

Transport vehicle

- Trolley 55-5

3.2 Documents which also apply

3.2.1 Warranty

 For more information refer to the "Warranty registration" brochure supplied and our information regarding warranty, maintenance and testing at www.ewm-group.com!

3.2.2 Declaration of Conformity

 The designated machine conforms to EC Directives and standards in terms of its design and construction:

- EC Low Voltage Directive (2006/95/EC),
- EC EMC Directive (2004/108/EC),

This declaration shall become null and void in the event of unauthorised modifications, improperly conducted repairs, non-observance of the deadlines for the repetition test and / or non-permitted conversion work not specifically authorised by the manufacturer.

The original copy of the declaration of conformity is enclosed with the unit.

3.2.3 Welding in environments with increased electrical hazards

 In compliance with IEC / DIN EN 60974, VDE 0544 the machines can be used in environments with an increased electrical hazard.

3.2.4 Service documents (spare parts and circuit diagrams)

 **DANGER**



Do not carry out any unauthorised repairs or modifications!

To avoid injury and equipment damage, the unit must only be repaired or modified by specialist, skilled persons!

The warranty becomes null and void in the event of unauthorised interference.

- Appoint only skilled persons for repair work (trained service personnel)!

Original copies of the circuit diagrams are enclosed with the unit.

Spare parts can be obtained from the relevant authorised dealer.

3.2.5 Calibration/Validation

We hereby confirm that this machine has been tested using calibrated measuring equipment, as stipulated in IEC/EN 60974, ISO/EN 17662, EN 50504, and complies with the admissible tolerances.

Recommended calibration interval: 12 months

4 Machine description – quick overview

4.1 Front view

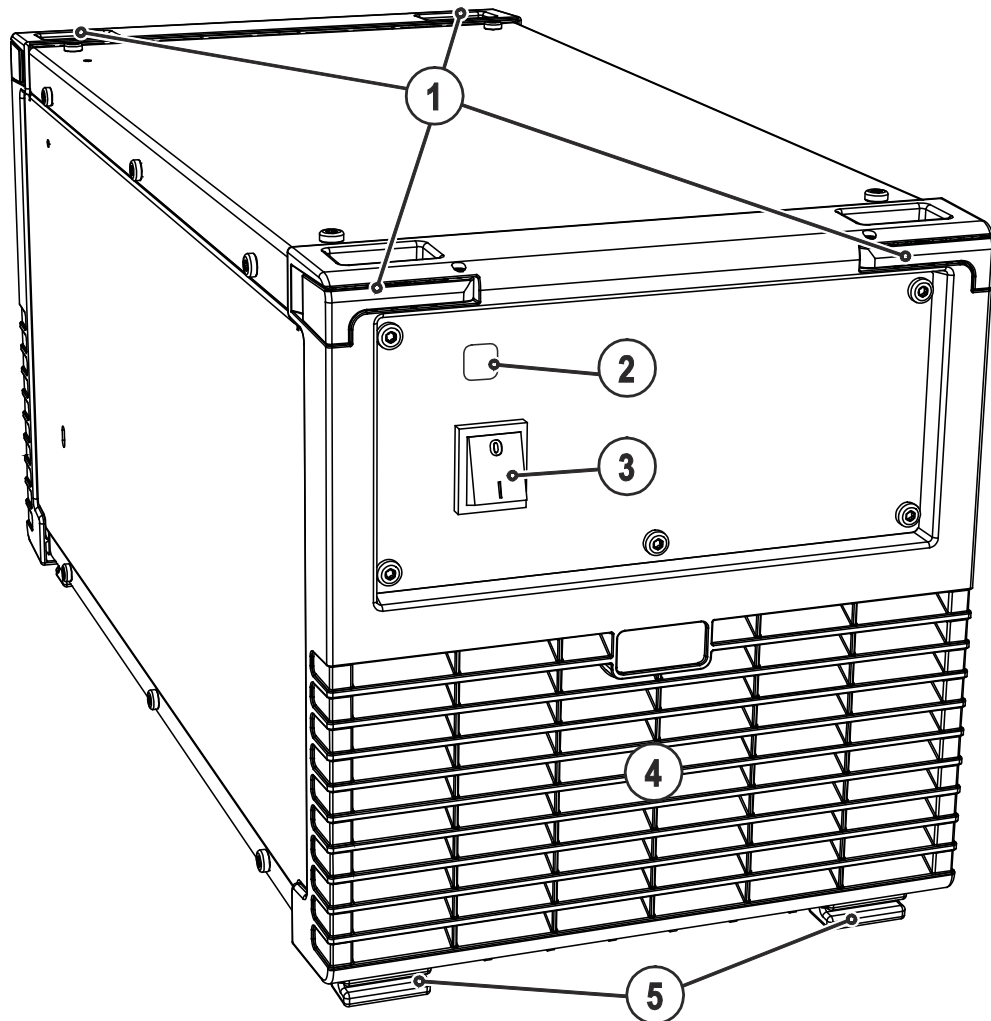

Figure 4-1

Item	Symbol	Description
1		Screw connector
2		Excess temperature signal light In case of excess temperature, temperature monitors de-activate the power unit, and the excess temperature control lamp comes on. Once the machine has cooled down, welding can continue without any further measures.
3		Main switch, machine on/off
4		Cooling air inlet
5		Machine feet

4.2 Rear view

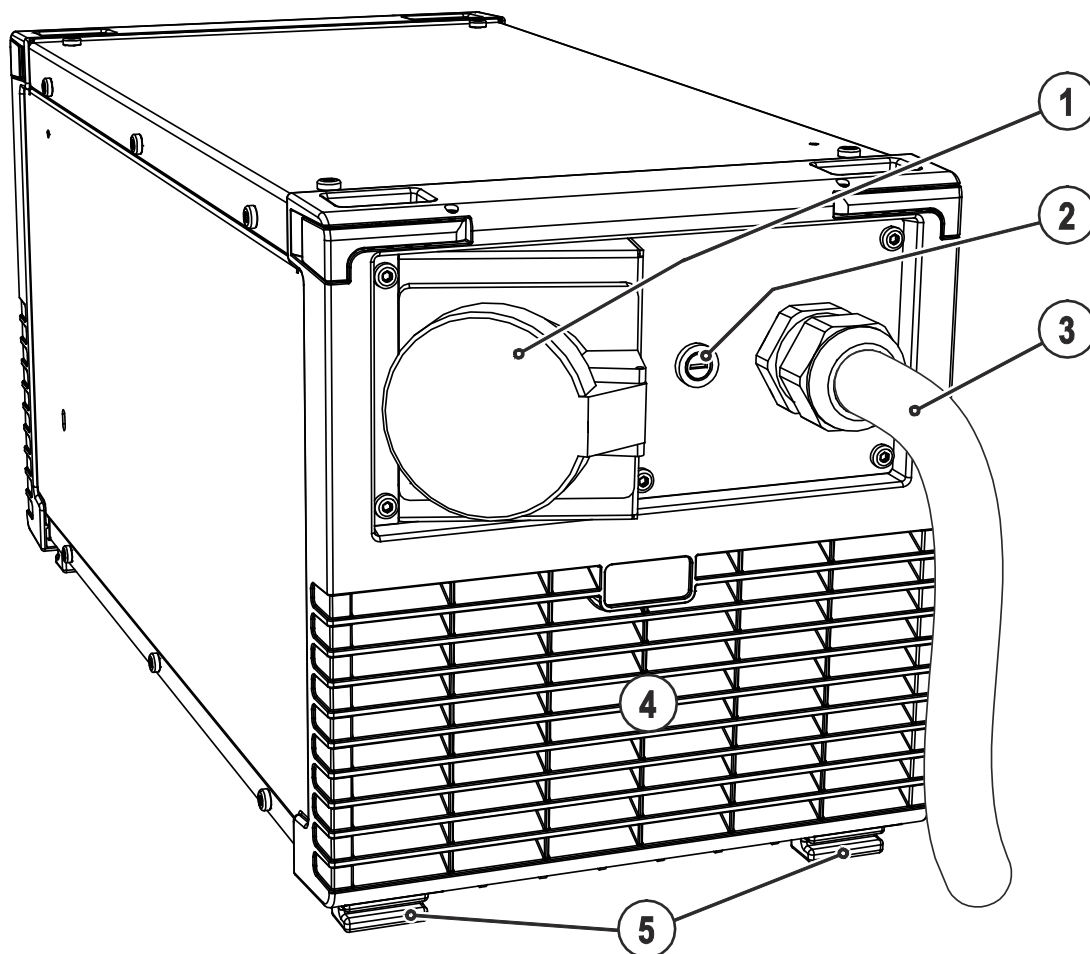

Figure 4-2

Item	Symbol	Description
1		Welding machine mains connection socket – 400 V CEE
2		Machine fuse (1A)
3		Mains connection cable - See 5.5 Mains connection chapter
4		Cooling air outlet
5		Machine feet

5 Design and function

5.1 General

WARNING



Risk of injury from electric shock!

Contact with live parts, e.g. welding current sockets, is potentially fatal!

- Follow safety instructions on the opening pages of the operating instructions.
- Commissioning may only be carried out by persons who have the relevant expertise of working with arc welding machines!
- Connection and welding leads (e.g. electrode holder, welding torch, workpiece lead, interfaces) may only be connected when the machine is switched off!



Observe documentation of other system components when connecting!

5.2 Machine cooling

To obtain an optimal duty cycle from the power components, the following precautions should be observed:

- Ensure that the working area is adequately ventilated.
- Do not obstruct the air inlets and outlets of the machine.
- Do not allow metal parts, dust or other objects to get into the machine.

5.3 Transport and installation

WARNING



Risk of accident due to improper transport of machines that may not be lifted!

Do not lift or suspend the machine! The machine can fall down and cause injuries! The handles and brackets are suitable for transport by hand only!

- The machine may not be lifted by crane or suspended!

CAUTION



Installation site!

The machine must not be operated in the open air and must only be set up and operated on a suitable, stable and level base!

- The operator must ensure that the ground is non-slip and level, and provide sufficient lighting for the place of work.
- Safe operation of the machine must be guaranteed at all times.

5.4 Assembly/disassembly

⚠ CAUTION



Risk of accidents due to improperly secured machines!

Depending on the machine series the transport vehicle has to be adapted to mount the machine. Failing to adapt the transport vehicle can cause the machine being transported to topple and lead to injuries!

- Following conversions and prior to each transport make sure all mounting elements are properly tightened!

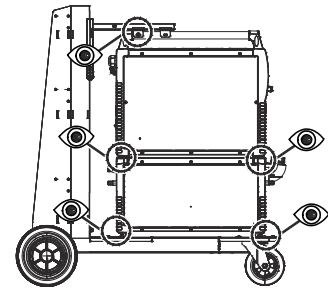

Damage due to supply lines not being disconnected!

During transport, supply lines which have not been disconnected (mains supply leads, control leads, etc.) may cause hazards such as connected equipment tipping over and injuring persons!

- Disconnect supply lines!



Assembly and disassembly is very simple and doesn't require any tools.

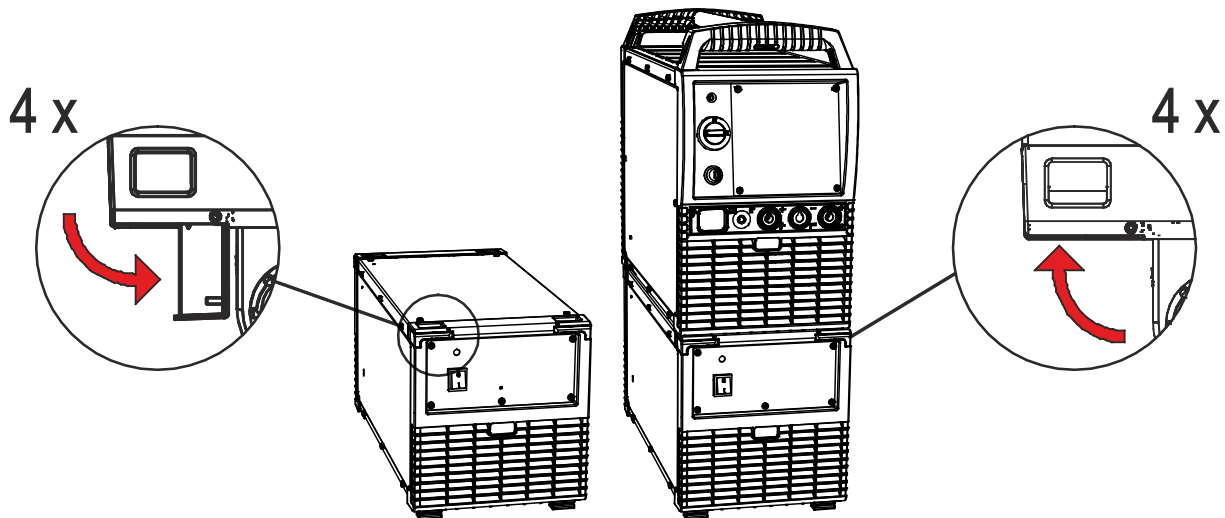

Figure 5-1

- Fold all four twist-off fasteners outwards until they will go no further.
- Fit welding machine with feet precisely into the designated twist-off fastener openings.
- Fold all four twist-off fasteners back into place until they will go no further.

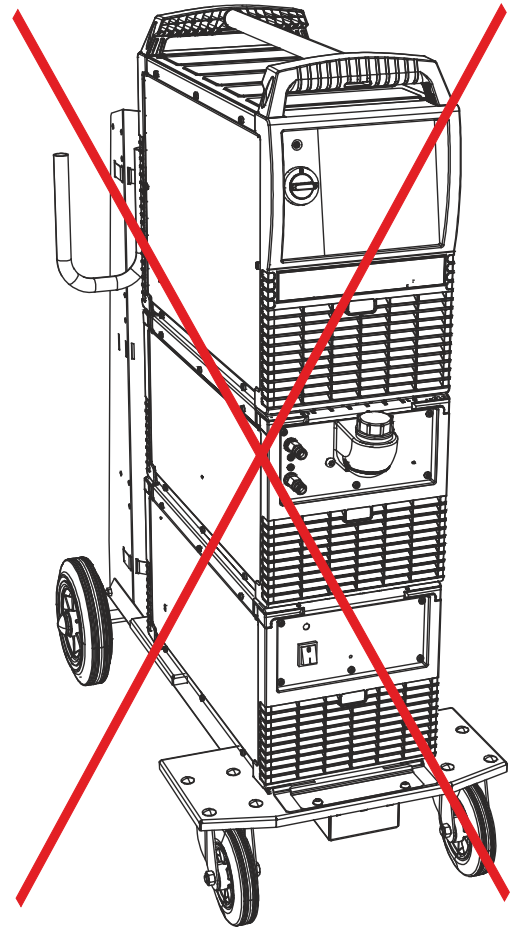
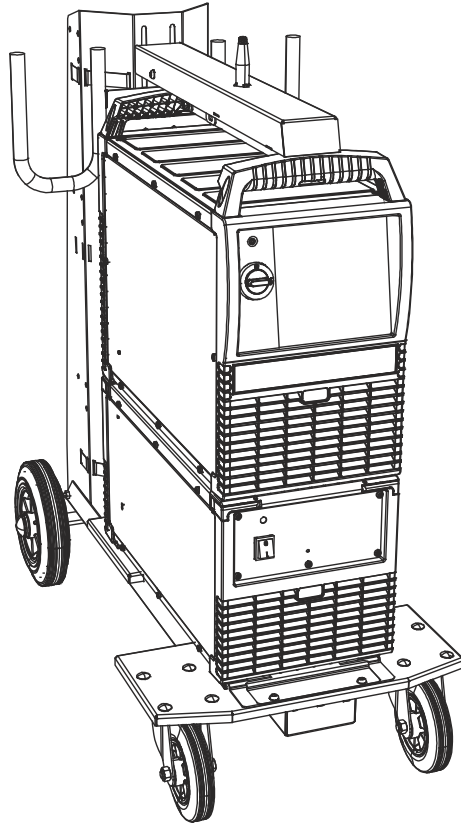

Figure 5-2

5.4.1 Power source connection

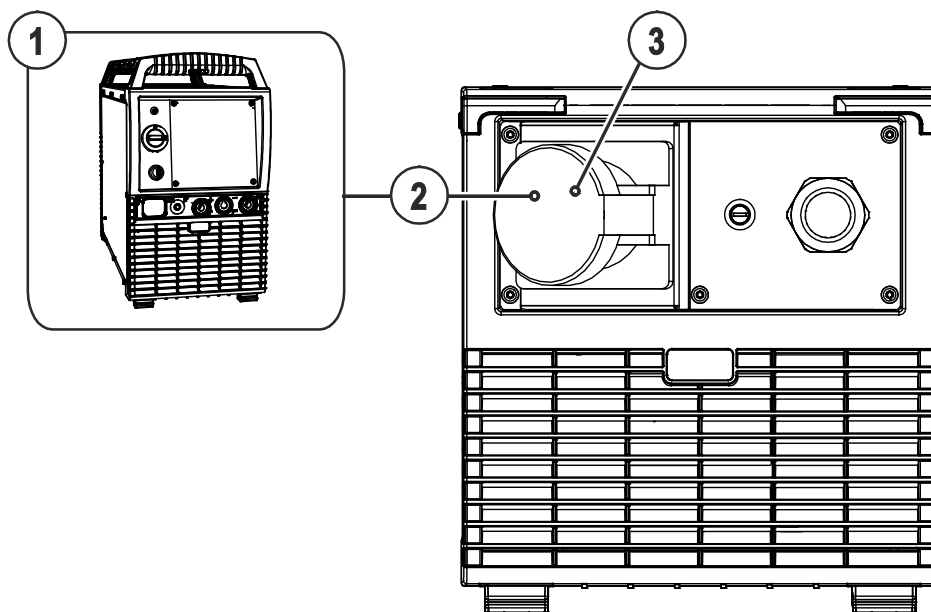

Figure 5-3

Item	Symbol	Description
1		Power source
2		Mains connection cable with connector plug
3		Welding machine mains connection socket Power supply for welding machine

- Insert mains plug from the disconnected machine into the appropriate socket on the power source.

5.5 Mains connection

⚠ DANGER



Hazard caused by improper mains connection!

An improper mains connection can cause injuries or damage property!

- Only use machine with a plug socket that has a correctly fitted protective conductor.
- If a mains plug must be fitted, this may only be carried out by an electrician in accordance with the relevant national provisions or regulations!
- Mains plug, socket and lead must be checked regularly by an electrician!
- When operating the generator always ensure it is earthed as stated in the operating instructions. The resulting network has to be suitable for operating devices according to protection class 1.

5.5.1 Mains configuration



The machine may be connected to:

- a three-phase system with four conductors and an earthed neutral conductor
- a three-phase system with three conductors of which any one can be earthed, e.g. the outer conductor

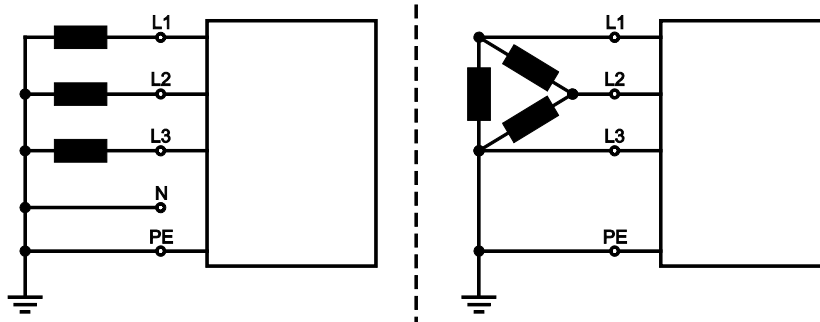

Figure 5-4

Legend

Item	Designation	Colour code
L1	Outer conductor 1	brown
L2	Outer conductor 2	black
L3	Outer conductor 3	grey
N	Neutral conductor	blue
PE	Protective conductor	green-yellow

CAUTION



Operating voltage - mains voltage!

The operating voltage shown on the rating plate must be consistent with the mains voltage, in order to avoid damage to the machine!

- - See 8 Technical data chapter!

- Insert mains plug of the switched-off machine into the appropriate socket.

6 Maintenance, care and disposal

DANGER



Do not carry out any unauthorised repairs or modifications!

To avoid injury and equipment damage, the unit must only be repaired or modified by specialist, skilled persons!

The warranty becomes null and void in the event of unauthorised interference.

- Appoint only skilled persons for repair work (trained service personnel)!



Risk of injury from electric shock!

Cleaning machines that are not disconnected from the mains can lead to serious injuries!

- Disconnect the machine completely from the mains.
- Remove the mains plug!
- Wait for 4 minutes until the capacitors have discharged!

Repair and maintenance work may only be performed by qualified authorised personnel; otherwise the right to claim under warranty is void. In all service matters, always consult the dealer who supplied the machine. Return deliveries of defective equipment subject to warranty may only be made through your dealer. When replacing parts, use only original spare parts. When ordering spare parts, please quote the machine type, serial number and item number of the machine, as well as the type designation and item number of the spare part.

6.1 General

When used in the specified environmental conditions and under normal operating conditions, this machine is largely maintenance-free and requires a minimum of care.

There are some points, which should be observed, to guarantee fault-free operation of your welding machine. Among these are regular cleaning and checking as described below, depending on the pollution level of the environment and the length of time the unit is in use.

6.2 Maintenance work, intervals

6.2.1 Daily maintenance tasks

6.2.1.1 Visual inspection

- Supply lines and their strain relief fittings
- Other, general condition

6.2.1.2 Functional test

- Operating, message, safety and adjustment devices (Functional test)

6.2.2 Monthly maintenance tasks

- Clean surfaces and glass with a damp cloth (do not use aggressive cleaning agents)!

6.2.2.1 Visual inspection

- Casing damage (front, rear and side walls)

6.2.3 Annual test (inspection and testing during operation)



The welding machine may only be tested by competent, capable persons!. A capable person is one who, because of his training, knowledge and experience, is able to recognise the dangers that can occur while testing welding power sources as well as possible subsequent damage and who is able to implement the required safety procedures.



For more information refer to the "Warranty registration" brochure supplied and our information regarding warranty, maintenance and testing at www.ewm-group.com!

A periodic test according to IEC 60974-4 "Periodic inspection and test" has to be carried out. In addition to the regulations on testing given here, the relevant local laws and regulations must also be observed.

6.3 Disposing of equipment



Proper disposal!

The machine contains valuable raw materials, which should be recycled, and electronic components, which must be disposed of.

- **Do not dispose of in household waste!**
- **Observe the local regulations regarding disposal!**



6.3.1 Manufacturer's declaration to the end user

- According to European provisions (guideline 2002/96/EG of the European Parliament and the Council of January, 27th 2003), used electric and electronic equipment may no longer be placed in unsorted municipal waste. It must be collected separately. The symbol depicting a waste container on wheels indicates that the equipment must be collected separately.
This machine is to be placed for disposal or recycling in the waste separation systems provided for this purpose.
- According to German law (law governing the distribution, taking back and environmentally correct disposal of electric and electronic equipment (ElektroG) from 16.03.2005), used machines are to be placed in a collection system separate from unsorted municipal waste. The public waste management utilities (communities) have created collection points at which used equipment from private households can be disposed of free of charge.
- Information about giving back used equipment or about collections can be obtained from the respective municipal administration office.
- EWM participates in an approved waste disposal and recycling system and is registered in the Used Electrical Equipment Register (EAR) under number WEEE DE 57686922.
- In addition to this, returns are also possible throughout Europe via EWM sales partners.

6.4 Meeting the requirements of RoHS

We, EWM AG Mündersbach, hereby confirm that all products supplied by us which are affected by the RoHS Directive, meet the requirements of the RoHS (Directive 2011/65/EU).

7 Rectifying faults

All products are subject to rigorous production checks and final checks. If, despite this, something fails to work at any time, please check the product using the following flowchart. If none of the fault rectification procedures described leads to the correct functioning of the product, please inform your authorised dealer.

7.1 Checklist for rectifying faults

 **The correct machine equipment for the material and process gas in use is a fundamental requirement for perfect operation!**

 **Please observe the welding machine operating instructions.**

Legend	Symbol	Description
	↗	Fault/Cause
	✘	Remedy

Excess temperature signal light illuminates

- ↗ Excess temperature, welding machine
- ✘ Allow the machine to cool down whilst still switched on

Functional errors

- ↗ Machine control without displaying the signal lights after switching on
 - ✘ Phase failure > check mains connection (fuses)
 - ✘ Check and replace if necessary
- ↗ Unsuitable mains fuse
 - ✘ Set up recommended mains fuse.

8 Technical data

 *Performance specifications and guarantee only in connection with original spare and replacement parts!*

8.1 voltConverter 230/400

Mains voltage (tolerances)	3 x 230 V (-25% to +20%)
Frequency	50/60Hz
Mains fuse (safety fuse, slow-blow)	3 x 55 A
Mains connection lead	H07RN-F4G10
Max. output current at 60% duty ratio	44 A
Max. output current at 100% duty ratio	32 A
Insulation class/protection classification	H/IP 23
Ambient temperature	-25 °C to +40 °C
Machine cooling	Fan
Dimensions L x W x H	610 x 300 x 330 mm
Weight	64.5 kg
EMC class	A
Constructed to standard	IEC 60974-1, -10, 61558-1 S / C E

9 Accessories

 *Performance-dependent accessories like torches, workpiece leads, electrode holders or intermediate hose packages are available from your authorised dealer.*

9.1 Transport systems

Type	Designation	Item no.
Trolley 55.2-2 II	Transport vehicle	090-008631-00000
Trolley 55-5	Transport cart, assembled	090-008632-00000
ON TR Trolley 55-5	Cross arm and holder for wire feeder	092-002700-00000
ON PS Trolley 55-5 drive 4L/4X	Pivot support	092-002712-00000

10 Appendix A

10.1 Overview of EWM branches

Headquarters

EWM AG
 Dr. Günter-Henle-Straße 8
 56271 Mündersbach · Germany
 Tel: +49 2680 181-0 · Fax: -244
www.ewm-group.com · info@ewm-group.com

Technology centre

EWM AG
 Forststraße 7-13
 56271 Mündersbach · Germany
 Tel: +49 2680 181-0 · Fax: -144
www.ewm-group.com · info@ewm-group.com



Production, Sales and Service

EWM AG
 Dr. Günter-Henle-Straße 8
 56271 Mündersbach · Germany
 Tel: +49 2680 181-0 · Fax: -244
www.ewm-group.com · info@ewm-group.com

EWM HIGH TECHNOLOGY (Kunshan) Ltd.
 10 Yuanshan Road, Kunshan · New & Hi-tech Industry Development Zone
 Kunshan City · Jiangsu · Post code 215300 · People's Republic of China
 Tel: +86 512 57867-188 · Fax: -182
www.ewm.cn · info@ewm.cn · info@ewm-group.cn

EWM HIGHTEC WELDING s.r.o.
 9. května 718 / 31
 407 53 Jirkov · Czech Republic
 Tel.: +420 412 358-551 · Fax: -504
www.ewm-jirkov.cz · info@ewm-jirkov.cz

Sales and Service Germany

EWM AG
 Sales and Technology Centre
 Grünauer Fenn 4
 14712 Rathenow · Tel: +49 3385 49402-0 · Fax: -20
www.ewm-rathenow.de · info@ewm-rathenow.de

EWM AG
 Rudolf-Winkel-Straße 7-9
 37079 Göttingen · Tel: +49 551-3070713-0 · Fax: -20
www.ewm-goettingen.de · info@ewm-goettingen.de

EWM AG
 Sachsstraße 28
 50259 Pulheim · Tel: +49 2234 697-047 · Fax: -048
www.ewm-pulheim.de · info@ewm-pulheim.de

EWM AG
 August-Horch-Straße 13a
 56070 Koblenz · Tel: +49 261 963754-0 · Fax: -10
www.ewm-koblenz.de · info@ewm-koblenz.de

EWM AG
 Eiserfelder Straße 300
 57080 Siegen · Tel: +49 271 3878103-0 · Fax: -9
www.ewm-siegen.de · info@ewm-siegen.de

EWM HIGHTEC WELDING GmbH
 Sales and Technology Centre
 Draistraße 2a
 69469 Weinheim · Tel: +49 6201 84557-0 · Fax: -20
www.ewm-weinheim.de · info@ewm-weinheim.de

EWM Schweißtechnik Handels GmbH
 Karlsdorfer Straße 43
 88069 Tettang · Tel: +49 7542 97998-0 · Fax: -29
www.ewm-tettang.de · info@ewm-tettang.de

EWM Schweißtechnik Handels GmbH
 Pfaffensteig 17
 89143 Blaubeuren · Tel: +49 7344 9191-75 · Fax: -77
www.ewm-blaubeuren.de · info@ewm-blaubeuren.de

EWM Schweißtechnik Handels GmbH
 Heinkelstraße 8
 89231 Neu-Ulm · Tel: +49 731 7047939-0 · Fax: -15
www.ewm-neu-ulm.de · info@ewm-neu-ulm.de

Sales and Service International

EWM HIGHTEC WELDING GmbH
 Wiesenstraße 27b
 4812 Pinsdorf · Austria · Tel: +43 7612 778 02-0 · Fax: -20
www.ewm-austria.at · info@ewm-austria.at

EWM HIGH TECHNOLOGY (Kunshan) Ltd.
 10 Yuanshan Road, Kunshan · New & Hi-tech Industry Development Zone
 Kunshan City · Jiangsu · Post code 215300 · People's Republic of China
 Tel: +86 512 57867-188 · Fax: -182
www.ewm.cn · info@ewm.cn · info@ewm-group.cn

EWM HIGHTEC WELDING UK Ltd.
 Unit 2B Coopies Way · Coopies Lane Industrial Estate
 Morpeth · Northumberland · NE61 6JN · Great Britain
 Tel: +44 1670 505875 · Fax: -514305
www.ewm-morpeth.co.uk · info@ewm-morpeth.co.uk

EWM HIGHTEC WELDING Sales s.r.o. / Prodejní a poradenské centrum
 Tyršova 2106
 256 01 Benešov u Prahy · Czech Republic
 Tel: +420 317 729-517 · Fax: -712
www.ewm-benesov.cz · info@ewm-benesov.cz

 Plants

 Branches

● More than 400 EWM sales partners worldwide