



Welding machine

**Pico 180**

**Pico 180 VRD**

**Pico 180 VRD 12V**

099-002003-EW501

20.01.2016

**Register now  
and benefit!  
Jetzt Registrieren  
und Profitieren!**

[www.ewm-group.com](http://www.ewm-group.com)



**3 Years** **5 Years**  
transformer  
and rectifier

**ewm-warranty\***  
24 hours / 7 days

\*For details visit  
[www.ewm-group.com](http://www.ewm-group.com)

# General instructions

## CAUTION



### **Read the operating instructions!**

**The operating instructions provide an introduction to the safe use of the products.**

- Read the operating instructions for all system components!
- Observe accident prevention regulations!
- Observe all local regulations!
- Confirm with a signature where appropriate.



***In the event of queries on installation, commissioning, operation or special conditions at the installation site, or on usage, please contact your sales partner or our customer service department on +49 2680 181-0.***

***A list of authorised sales partners can be found at [www.ewm-group.com](http://www.ewm-group.com).***

Liability relating to the operation of this equipment is restricted solely to the function of the equipment. No other form of liability, regardless of type, shall be accepted. This exclusion of liability shall be deemed accepted by the user on commissioning the equipment.

The manufacturer is unable to monitor whether or not these instructions or the conditions and methods are observed during installation, operation, usage and maintenance of the equipment. An incorrectly performed installation can result in material damage and injure persons as a result. For this reason, we do not accept any responsibility or liability for losses, damages or costs arising from incorrect installation, improper operation or incorrect usage and maintenance or any actions connected to this in any way.

© EWM AG · Dr. Günter-Henle-Str. 8 · D-56271 Mündersbach, Germany

The copyright to this document remains the property of the manufacturer.

Reprinting, including extracts, only permitted with written approval.

The content of this document has been prepared and reviewed with all reasonable care. The information provided is subject to change, errors excepted.

# 1 Contents

<b>1</b>	<b>Contents</b>	<b>3</b>
<b>2</b>	<b>Safety instructions</b>	<b>5</b>
2.1	Notes on the use of these operating instructions	5
2.2	Explanation of icons	6
2.3	General	7
2.4	Transport and installation	11
2.4.1	Ambient conditions	12
2.4.1.1	In operation	12
2.4.1.2	Transport and storage	12
<b>3</b>	<b>Intended use</b>	<b>13</b>
3.1	Documents which also apply	13
3.1.1	Warranty	13
3.1.2	Declaration of Conformity	13
3.1.3	Welding in environments with increased electrical hazards	13
3.1.4	Service documents (spare parts and circuit diagrams)	13
3.1.5	Calibration/Validation	13
<b>4</b>	<b>Machine description – quick overview</b>	<b>14</b>
4.1	Front view	14
4.2	Rear view	15
4.3	Machine control – Operating elements	16
<b>5</b>	<b>Design and function</b>	<b>18</b>
5.1	General	18
5.2	Workpiece lead, general	19
5.3	Transport and installation	19
5.3.1	Adjusting the length of the carrying strap	19
5.4	Machine cooling	19
5.5	Notes on the installation of welding current leads	20
5.6	Mains connection	22
5.6.1	Mains configuration	22
5.7	MMA welding	23
5.7.1	Connecting the electrode holder and workpiece lead	23
5.7.2	Selecting MMA welding	24
5.7.3	Hotstart current and Hotstart time	24
5.7.4	Antistick	25
5.7.5	Average value pulse welding	25
5.7.6	Expert menu (MMA)	27
5.8	TIG welding	28
5.8.1	Shielding gas supply (shielding gas cylinder for welding machine)	28
5.8.1.1	Connecting the shielding gas supply	29
5.8.2	Connecting a TIG welding torch with rotating gas valve	30
5.8.3	TIG welding selection	31
5.8.4	TIG arc ignition	31
5.8.5	Average value pulse welding	31
5.8.6	Expert menu (TIG)	33
5.9	Dirt filter	34
5.10	Power-saving mode (Standby)	35
5.11	Remote control	35
5.11.1	RT1 19POL	35
5.11.2	RTG1 19POL	35
5.11.3	RTF1 19POL	35
5.12	Voltage reducing device	35
5.13	Machine configuration menu	36
<b>6</b>	<b>Maintenance, care and disposal</b>	<b>38</b>
6.1	General	38
6.2	Maintenance work, intervals	38
6.2.1	Daily maintenance tasks	38

6.2.1.1	Visual inspection .....	38
6.2.1.2	Functional test .....	38
6.2.2	Monthly maintenance tasks .....	38
6.2.2.1	Visual inspection .....	38
6.2.2.2	Functional test .....	38
6.2.3	Annual test (inspection and testing during operation) .....	39
6.3	Disposing of equipment.....	39
6.3.1	Manufacturer's declaration to the end user .....	39
6.4	Meeting the requirements of RoHS.....	39
<b>7</b>	<b>Rectifying faults.....</b>	<b>40</b>
7.1	Checklist for rectifying faults .....	40
7.2	Machine faults (error messages) .....	41
7.3	Display machine control software version.....	42
7.4	Dynamic power adjustment.....	42
7.5	Resetting welding parameters to the factory settings .....	42
<b>8</b>	<b>Technical data.....</b>	<b>43</b>
8.1	Pico 180 .....	43
<b>9</b>	<b>Accessories .....</b>	<b>44</b>
9.1	Transport systems.....	44
9.2	Remote controls and accessories.....	44
9.3	General accessories .....	44
<b>10</b>	<b>Appendix A.....</b>	<b>45</b>
10.1	Overview of EWM branches.....	45

## 2 Safety instructions

### 2.1 Notes on the use of these operating instructions

#### **DANGER**

**Working or operating procedures which must be closely observed to prevent imminent serious and even fatal injuries.**

- Safety notes include the "DANGER" keyword in the heading with a general warning symbol.
- The hazard is also highlighted using a symbol on the edge of the page.

#### **WARNING**

**Working or operating procedures which must be closely observed to prevent serious and even fatal injuries.**

- Safety notes include the "WARNING" keyword in the heading with a general warning symbol.
- The hazard is also highlighted using a symbol in the page margin.

#### **CAUTION**

**Working or operating procedures which must be closely observed to prevent possible minor personal injury.**

- The safety information includes the "CAUTION" keyword in its heading with a general warning symbol.
- The risk is explained using a symbol on the edge of the page.

#### **CAUTION**

**Working and operating procedures which must be followed precisely to avoid damaging or destroying the product.**















- The safety information includes the "CAUTION" keyword in its heading without a general warning symbol.
- The hazard is explained using a symbol at the edge of the page.

#### **Special technical points which users must observe.**

Instructions and lists detailing step-by-step actions for given situations can be recognised via bullet points, e.g.:

- Insert the welding current lead socket into the relevant socket and lock.

## 2.2 Explanation of icons

Symbol	Description
	Special technical points which users must observe.
	Correct
	Wrong
	Press
	Do not press
	Press and keep pressed
	Turn
	Switch
	Switch off machine
	Switch on machine
<b>ENTER</b>	enter the menu
<b>NAVIGATION</b>	Navigating in the menu
<b>EXIT</b>	Exit the menu
4 s 	Time display (example: wait 4s/press)
	Interruption in the menu display (other setting options possible)
	Tool not required/do not use
	Tool required/use

## 2.3 General

### **DANGER**



#### **Electromagnetic fields!**

The power source may cause electrical or electromagnetic fields to be produced which could affect the correct functioning of electronic equipment such as IT or CNC devices, telecommunication lines, power cables, signal lines and pacemakers.

- Observe the maintenance instructions - See 6 Maintenance, care and disposal chapter!
- Unwind welding leads completely!
- Shield devices or equipment sensitive to radiation accordingly!
- The correct functioning of pacemakers may be affected (obtain advice from a doctor if necessary).



#### **Do not carry out any unauthorised repairs or modifications!**

To avoid injury and equipment damage, the unit must only be repaired or modified by specialist, skilled persons!

The warranty becomes null and void in the event of unauthorised interference.

- Appoint only skilled persons for repair work (trained service personnel)!



#### **Electric shock!**

Welding machines use high voltages which can result in potentially fatal electric shocks and burns on contact. Even low voltages can cause you to get a shock and lead to accidents.

- Do not touch any live parts in or on the machine!
- Connection cables and leads must be free of faults!
- Switching off alone is not sufficient!
- Place welding torch and stick electrode holder on an insulated surface!
- The unit should only be opened by specialist staff after the mains plug has been unplugged!
- Only wear dry protective clothing!
- Wait for 4 minutes until the capacitors have discharged!

### **WARNING**



#### **Risk of injury due to radiation or heat!**

Arc radiation results in injury to skin and eyes.

Contact with hot workpieces and sparks results in burns.

- Use welding shield or welding helmet with the appropriate safety level (depending on the application)!
- Wear dry protective clothing (e.g. welding shield, gloves, etc.) according to the relevant regulations in the country in question!
- Protect persons not involved in the work against arc beams and the risk of glare using safety curtains!



#### **Explosion risk!**

Apparently harmless substances in closed containers may generate excessive pressure when heated.

- Move containers with inflammable or explosive liquids away from the working area!
- Never heat explosive liquids, dusts or gases by welding or cutting!

## WARNING



### Smoke and gases!

**Smoke and gases can lead to breathing difficulties and poisoning. In addition, solvent vapour (chlorinated hydrocarbon) may be converted into poisonous phosgene due to the ultraviolet radiation of the arc!**

- Ensure that there is sufficient fresh air!
- Keep solvent vapour away from the arc beam field!
- Wear suitable breathing apparatus if appropriate!



### Fire hazard!

**Flames may arise as a result of the high temperatures, stray sparks, glowing-hot parts and hot slag produced during the welding process.**

**Stray welding currents can also result in flames forming!**

- Check for fire hazards in the working area!
- Do not carry any easily flammable objects such as matches or lighters.
- Keep appropriate fire extinguishing equipment to hand in the working area!
- Thoroughly remove any residue of flammable substances from the workpiece before starting welding.
- Only continue work on welded workpieces once they have cooled down. Do not allow to come into contact with flammable material!
- Connect welding leads correctly!



### Risk of accidents due to non-compliance with the safety instructions!

**Non-compliance with the safety instructions can be fatal!**

- Carefully read the safety instructions in this manual!
- Observe the accident prevention regulations and any regional regulations!
- Inform persons in the working area that they must comply with the regulations!



### Danger when coupling multiple power sources!

**Coupling multiple power sources in parallel or in series has to be carried out by qualified personnel and in accordance with the manufacturer's guidelines. Before bringing the power sources into service for arc welding operations, a test has to verify that they cannot exceed the maximum allowed open circuit voltage.**

- Connection of the machine may be carried out by qualified personnel only!
- When decommissioning individual power sources, all mains and welding current leads have to be safely disconnected from the welding system as a whole. (Danger due to inverse voltages!)
- Do not couple welding machines with pole reversing switch (PWS series) or machines for AC welding, as a minor error in operation can cause the welding voltages to be combined.

## CAUTION



### Noise exposure!

**Noise exceeding 70 dBA can cause permanent hearing damage!**

- Wear suitable ear protection!
- Persons located within the working area must wear suitable ear protection!



**CAUTION****Obligations of the operator!****The respective national directives and laws must be observed for operation of the machine!**

- National implementation of the framework directive (89/391/EWG), as well as the associated individual directives.
- In particular, directive (89/655/EWG), on the minimum regulations for safety and health protection when staff members use equipment during work.
- The regulations regarding work safety and accident prevention for the respective country.
- Setting up and operating the machine according to IEC 60974-9.
- Check at regular intervals that users are working in a safety-conscious way.
- Regular checks of the machine according to IEC 60974-4.

**Damage due to the use of non-genuine parts!****The manufacturer's warranty becomes void if non-genuine parts are used!**

- Only use system components and options (power sources, welding torches, electrode holders, remote controls, spare parts and replacement parts, etc.) from our range of products!
- Only insert and lock accessory components into the relevant connection socket when the machine is switched off.

**Damage to the machine due to stray welding currents!****Stray welding currents can destroy protective earth conductors, damage equipment and electronic devices and cause overheating of components leading to fire.**

- Make sure all welding leads are securely connected and check regularly.
- Always ensure a proper and secure electrical connection to the workpiece!
- Set up, attach or suspend all conductive power source components like casing, transport vehicle and crane frames so they are insulated!
- Do not place any other electronic devices such as drillers or angle grinders, etc., on the power source, transport vehicle or crane frames unless they are insulated!
- Always put welding torches and electrode holders on an insulated surface when they are not in use!

**Mains connection****Requirements for connection to the public mains network**

High-performance machines can influence the mains quality by taking current from the mains network. For some types of machines, connection restrictions or requirements relating to the maximum possible line impedance or the necessary minimum supply capacity at the interface with the public network (Point of Common Coupling, PCC) can therefore apply. In this respect, attention is also drawn to the machines' technical data. In this case, it is the responsibility of the operator, where necessary in consultation with the mains network operator, to ensure that the machine can be connected.

## CAUTION



### EMC Machine Classification

In accordance with IEC 60974-10, welding machines are grouped in two electromagnetic compatibility classes - See 8 Technical data chapter:

**Class A** machines are not intended for use in residential areas where the power supply comes from the low-voltage public mains network. When ensuring the electromagnetic compatibility of class A machines, difficulties can arise in these areas due to interference not only in the supply lines but also in the form of radiated interference.

**Class B** machines fulfil the EMC requirements in industrial as well as residential areas, including residential areas connected to the low-voltage public mains network.

### Setting up and operating

When operating arc welding systems, in some cases, electro-magnetic interference can occur although all of the welding machines comply with the emission limits specified in the standard. The user is responsible for any interference caused by welding.

In order to **evaluate** any possible problems with electromagnetic compatibility in the surrounding area, the user must consider the following: (see also EN 60974-10 Appendix A)

- Mains, control, signal and telecommunication lines
- Radios and televisions
- Computers and other control systems
- Safety equipment
- The health of neighbouring persons, especially if they have a pacemaker or wear a hearing aid
- Calibration and measuring equipment
- The immunity to interference of other equipment in the surrounding area
- The time of day at which the welding work must be carried out

### Recommendations for **reducing interference emission**

- Mains connection, e.g. additional mains filter or shielding with a metal tube
- Maintenance of the arc welding equipment
- Welding leads should be as short as possible and run closely together along the ground
- Potential equalization
- Earthing of the workpiece. In cases where it is not possible to earth the workpiece directly, it should be connected by means of suitable capacitors.
- Shielding from other equipment in the surrounding area or the entire welding system

## 2.4 Transport and installation

### WARNING



#### **Incorrect handling of shielding gas cylinders!**

**Incorrect handling of shielding gas cylinders can result in serious and even fatal injury.**

- Observe the instructions from the gas manufacturer and in any relevant regulations concerning the use of compressed air!
- Place shielding gas cylinders in the holders provided for them and secure with fixing devices.
- Avoid heating the shielding gas cylinder!



#### **Risk of accident due to improper transport of machines that may not be lifted!**

**Do not lift or suspend the machine! The machine can fall down and cause injuries! The handles and brackets are suitable for transport by hand only!**

- The machine may not be lifted by crane or suspended!

### CAUTION



#### **Risk of tipping!**

**There is a risk of the machine tipping over and injuring persons or being damaged itself during movement and set up. Tilt resistance is guaranteed up to an angle of 10° (according to IEC 60974-1).**

- Set up and transport the machine on level, solid ground.
- Secure add-on parts using suitable equipment.



#### **Damage due to supply lines not being disconnected!**

**During transport, supply lines which have not been disconnected (mains supply leads, control leads, etc.) may cause hazards such as connected equipment tipping over and injuring persons!**

- Disconnect supply lines!

### CAUTION



#### **Equipment damage when not operated in an upright position!**

**The units are designed for operation in an upright position!**

**Operation in non-permissible positions can cause equipment damage.**

- Only transport and operate in an upright position!

## 2.4.1 Ambient conditions

### CAUTION



#### Installation site!

**The machine must not be operated in the open air and must only be set up and operated on a suitable, stable and level base!**

- The operator must ensure that the ground is non-slip and level, and provide sufficient lighting for the place of work.
- Safe operation of the machine must be guaranteed at all times.

### CAUTION



#### Equipment damage due to dirt accumulation!

**Unusually high quantities of dust, acid, corrosive gases or substances may damage the equipment.**

- Avoid high volumes of smoke, vapour, oil vapour and grinding dust!
- Avoid ambient air containing salt (sea air)!



#### Non-permissible ambient conditions!

**Insufficient ventilation results in a reduction in performance and equipment damage.**

- Observe the ambient conditions!
- Keep the cooling air inlet and outlet clear!
- Observe the minimum distance of 0.5 m from obstacles!

### 2.4.1.1 In operation

#### Temperature range of the ambient air:

- -25 °C to +40 °C

#### Relative air humidity:

- Up to 50% at 40 °C
- Up to 90% at 20 °C

### 2.4.1.2 Transport and storage

#### Storage in an enclosed space, temperature range of the ambient air:

- -30 °C to +70 °C

#### Relative air humidity

- Up to 90% at 20 °C

### 3 Intended use

#### WARNING



##### **Hazards due to improper usage!**

**Hazards may arise for persons, animals and material objects if the equipment is not used correctly. No liability is accepted for any damages arising from improper usage!**

- The equipment must only be used in line with proper usage and by trained or expert staff!
- Do not modify or convert the equipment improperly!

Arc welding machine for MMA DC welding with TIG DC welding with lift arc (touch starting) as secondary process.

#### 3.1 Documents which also apply

##### 3.1.1 Warranty



*For more information refer to the "Warranty registration" brochure supplied and our information regarding warranty, maintenance and testing at [www.ewm-group.com](http://www.ewm-group.com)!*

##### 3.1.2 Declaration of Conformity



**The designated machine conforms to EC Directives and standards in terms of its design and construction:**

- EC Low Voltage Directive (2006/95/EC),
- EC EMC Directive (2004/108/EC),

This declaration shall become null and void in the event of unauthorised modifications, improperly conducted repairs, non-observance of the deadlines for the repetition test and / or non-permitted conversion work not specifically authorised by the manufacturer.

The original copy of the declaration of conformity is enclosed with the unit.

##### 3.1.3 Welding in environments with increased electrical hazards



**In compliance with IEC / DIN EN 60974, VDE 0544 the machines can be used in environments with an increased electrical hazard.**

##### 3.1.4 Service documents (spare parts and circuit diagrams)

#### DANGER



**Do not carry out any unauthorised repairs or modifications!**

**To avoid injury and equipment damage, the unit must only be repaired or modified by specialist, skilled persons!**

**The warranty becomes null and void in the event of unauthorised interference.**

- Appoint only skilled persons for repair work (trained service personnel)!

Original copies of the circuit diagrams are enclosed with the unit.

Spare parts can be obtained from the relevant authorised dealer.

##### 3.1.5 Calibration/Validation

We hereby confirm that this machine has been tested using calibrated measuring equipment, as stipulated in IEC/EN 60974, ISO/EN 17662, EN 50504, and complies with the admissible tolerances. Recommended calibration interval: 12 months

## 4 Machine description – quick overview

### 4.1 Front view

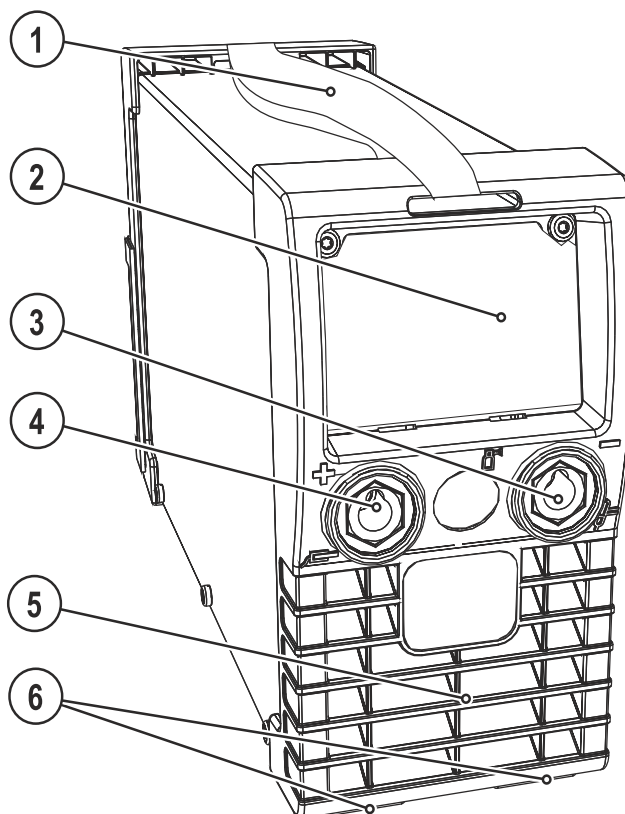

Figure 4-1

Item	Symbol	Description
1		<b>Carrying strap - See 5.3.1 Adjusting the length of the carrying strap chapter</b>
2		<b>Machine control- See 4.3 Machine control – Operating elements chapter</b>
3	—	<b>Connection socket, "-" welding current</b> <ul style="list-style-type: none"> <li>• TIG: Welding current lead connection for TIG welding torch</li> <li>• MMA: Electrode holder or workpiece lead connection</li> </ul>
4	+	<b>Connection socket, "+" welding current</b> <ul style="list-style-type: none"> <li>• TIG: Connection for workpiece lead</li> <li>• MMA: Electrode holder or workpiece lead connection</li> </ul>
5		<b>Cooling air outlet</b>
6		<b>Machine feet</b>

## 4.2 Rear view

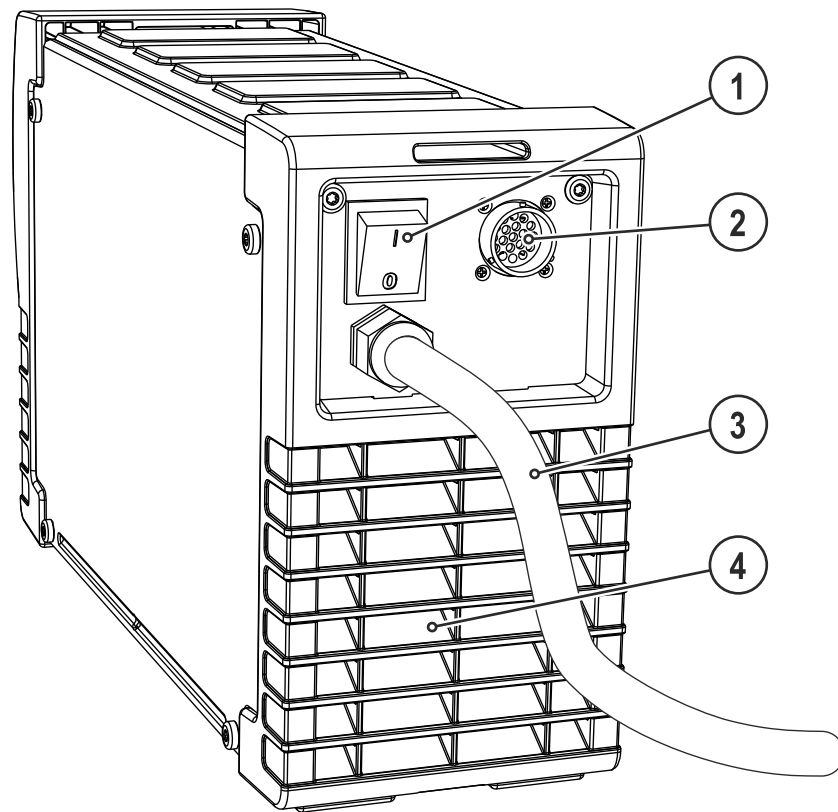



Figure 4-2

Item	Symbol	Description
1		<b>Main switch, machine on/off</b>
2		<b>Connection socket, 19-pole</b> Remote control connection
3		<b>Mains connection cable</b> - See 5.6 Mains connection chapter
4		<b>Cooling air inlet</b>

## 4.3 Machine control – Operating elements

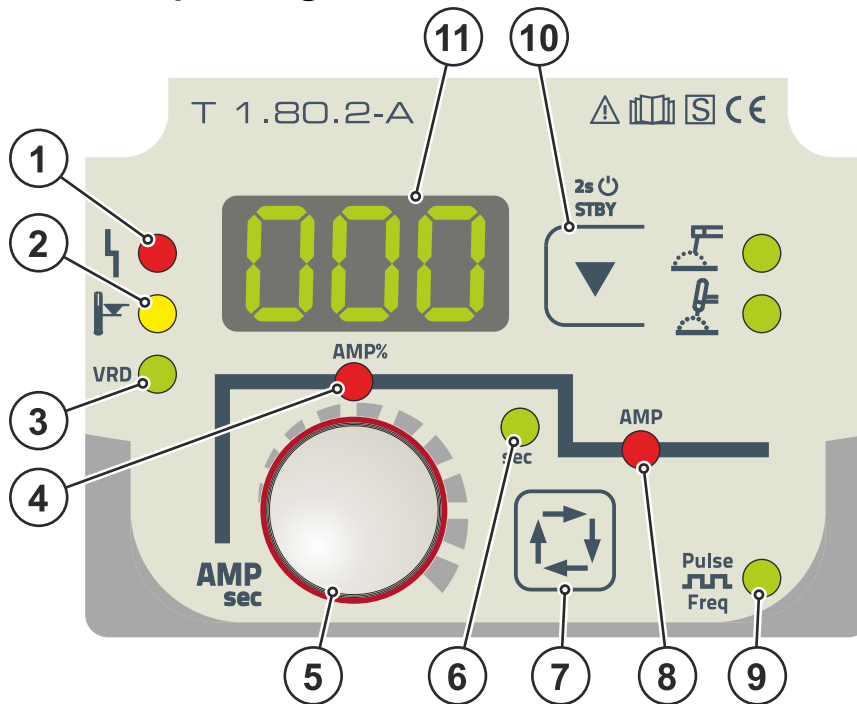





Figure 4-3

Item	Symbol	Description
1		<b>Collective interference signal light</b> For error messages, - See 7 Rectifying faults chapter
2		<b>Excess temperature signal light</b> In case of excess temperature, temperature monitors de-activate the power unit, and the excess temperature control lamp comes on. Once the machine has cooled down, welding can continue without any further measures.
3	VRD	<b>Voltage reduction device (VRD) signal light</b> The VRD signal light is illuminated when the voltage reduction device is operating without fault and the output voltage is reduced to a value specified in the relevant standard (see technical data). The voltage reduction device is only active on VRD machine versions.
4	AMP%	<b>Hotstart current signal light</b> 50 % to 200 % of the main current
5		<b>Welding parameter setting rotary transducer</b> Setting of welding current and other welding parameter and their values
6	sec	<b>Hotstart time signal light (0.1 s to 20 s)</b>
7		<b>Select welding parameters button</b> This button is used to select the welding parameters depending on the welding process and operating mode used.
8	AMP	<b>Main current signal light</b> I <sub>min</sub> to I <sub>max</sub> (1 A increments)
9		<b>Pulse welding (average value pulses) signal light</b> On: Function switched on <input type="checkbox"/> ON Not on: Function switched off <input type="checkbox"/> OFF Flashing: Parameter selection and frequency setting <input type="checkbox"/> F.F.F.:



Item	Symbol	Description
10		<b>Welding procedure/power-saving mode push-button</b>  MMA welding  TIG welding Press for 2 s to put the machine into power-saving mode. To reactivate, activate one of the operating elements.
11		<b>Display, 3-digit</b>

## 5 Design and function

### 5.1 General

#### WARNING



##### **Risk of injury from electric shock!**

**Contact with live parts, e.g. welding current sockets, is potentially fatal!**

- Follow safety instructions on the opening pages of the operating instructions.
- Commissioning may only be carried out by persons who have the relevant expertise of working with arc welding machines!
- Connection and welding leads (e.g. electrode holder, welding torch, workpiece lead, interfaces) may only be connected when the machine is switched off!

#### CAUTION



##### **Insulate the arc welder from welding voltage!**

**Not all active parts of the welding current circuit can be shielded from direct contact. To avoid any associated risks it is vital for the welder to adhere to the relevant safety regulations. Even low voltages can cause a shock and lead to accidents.**

- Wear dry and undamaged protective clothing (shoes with rubber soles/welder's gloves made from leather without any studs or braces)!
- Avoid direct contact with non-insulated connection sockets or connectors!
- Always place torches and electrode holders on an insulated surface!



##### **Risk of burns on the welding current connection!**

**If the welding current connections are not locked, connections and leads heat up and can cause burns, if touched!**

- Check the welding current connections every day and lock by turning in clockwise direction, if necessary.



##### **Risk from electrical current!**

**If welding is carried out alternately using different methods and if a welding torch and an electrode holder remain connected to the machine, the open-circuit/welding voltage is applied simultaneously on all cables.**

- The torch and the electrode holder should therefore always be placed on an insulated surface before starting work and during breaks.

#### CAUTION



##### **Damage due to incorrect connection!**

**Accessory components and the power source itself can be damaged by incorrect connection!**

- Only insert and lock accessory components into the relevant connection socket when the machine is switched off.
- Comprehensive descriptions can be found in the operating instructions for the relevant accessory components.
- Accessory components are detected automatically after the power source is switched on.



##### **Using protective dust caps!**

**Protective dust caps protect the connection sockets and therefore the machine against dirt and damage.**

- The protective dust cap must be fitted if there is no accessory component being operated on that connection.
- The cap must be replaced if faulty or if lost!

## 5.2 Workpiece lead, general

### CAUTION



**Risk of burns due to incorrect connection of the workpiece lead!**

Paint, rust and dirt on the connection restrict the power flow and may lead to stray welding currents.

**Stray welding currents may cause fires and injuries!**

- Clean the connections!
- Fix the workpiece lead securely!
- Do not use structural parts of the workpiece as a return lead for the welding current!
- Take care to ensure faultless power connections!

## 5.3 Transport and installation

### WARNING



**Risk of accident due to improper transport of machines that may not be lifted!**

**Do not lift or suspend the machine! The machine can fall down and cause injuries! The handles and brackets are suitable for transport by hand only!**

- The machine may not be lifted by crane or suspended!

### CAUTION



**Installation site!**

**The machine must not be operated in the open air and must only be set up and operated on a suitable, stable and level base!**

- The operator must ensure that the ground is non-slip and level, and provide sufficient lighting for the place of work.
- Safe operation of the machine must be guaranteed at all times.

### 5.3.1 Adjusting the length of the carrying strap



*To demonstrate adjustment, lengthening the strap is shown in the figure. To shorten, the strap's loops must be inched in the opposite direction.*

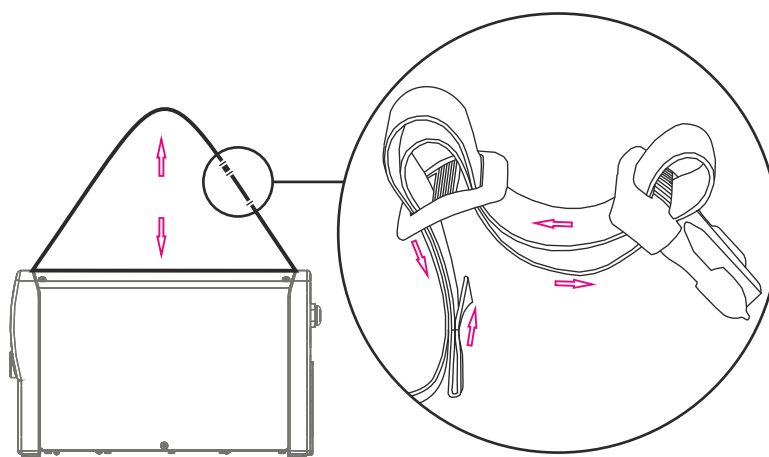







Figure 5-1

## 5.4 Machine cooling

To obtain an optimal duty cycle from the power components, the following precautions should be observed:

- Ensure that the working area is adequately ventilated.
- Do not obstruct the air inlets and outlets of the machine.
- Do not allow metal parts, dust or other objects to get into the machine.

## 5.5 Notes on the installation of welding current leads

-  **Incorrectly installed welding current leads can cause faults in the arc (flickering).**
-  **Lay the workpiece lead and hose package of power sources without HF igniter (MIG/MAG) for as long and as close as possible in parallel.**
-  **Lay the workpiece lead and hose package of power sources with HF igniter (TIG) for as long as possible in parallel with a distance of 20 cm to avoid HF sparkover.**
-  **Always keep a distance of at least 20 cm to leads of other power sources to avoid interferences**
-  **Always keep leads as short as possible! For optimum welding results max. 30 m (welding lead + intermediate hose package + torch lead).**

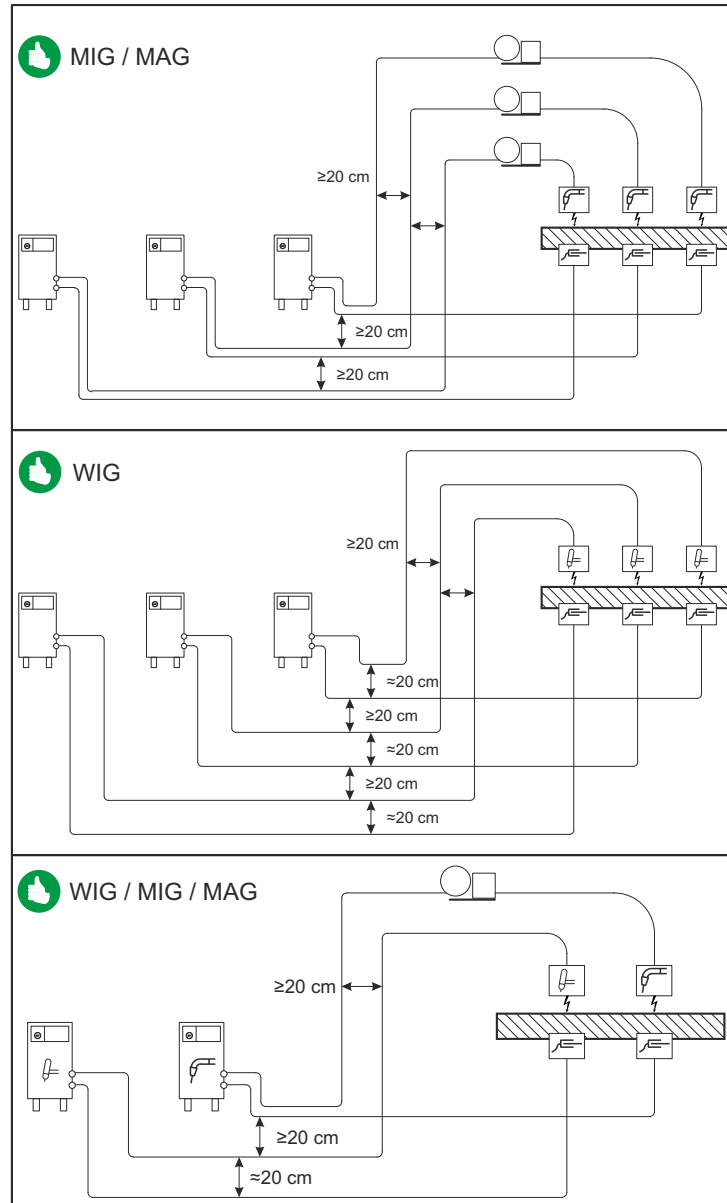

Figure 5-2

**Use an individual welding lead to the workpiece for each welding machine!**

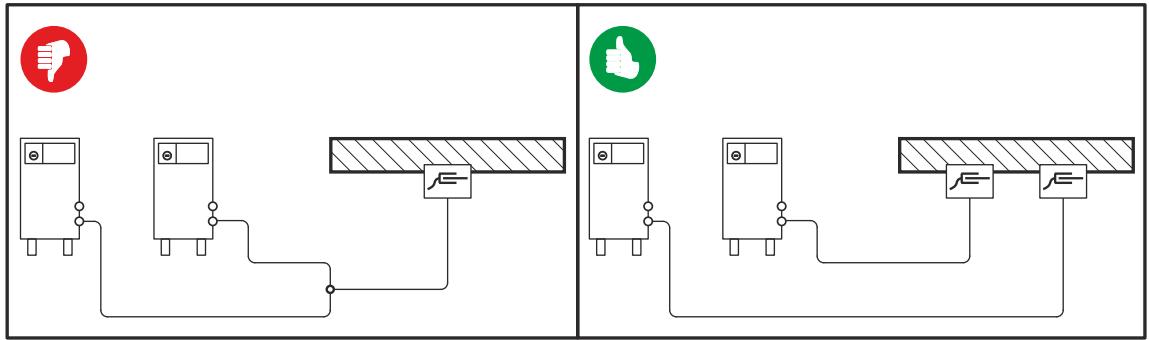

Figure 5-3

**Fully unroll welding current leads, torch hose packages and intermediate hose packages. Avoid loops!**

**Always keep leads as short as possible!**

**Lay any excess cable lengths in meanders.**

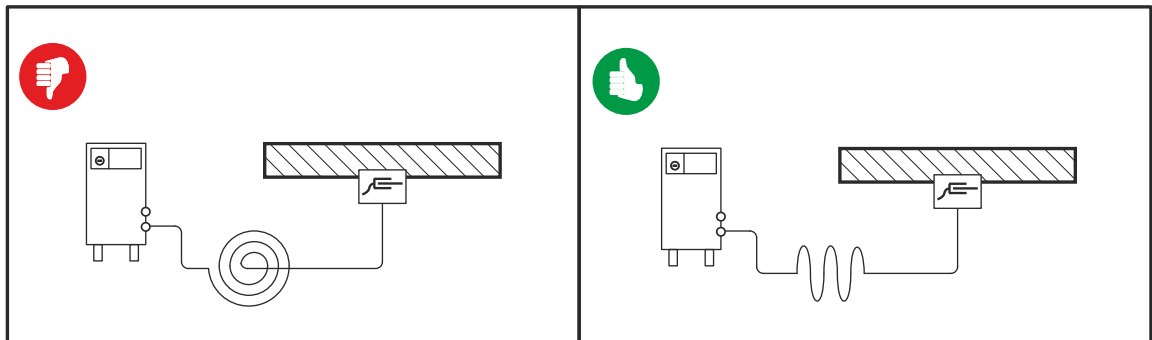

Figure 5-4

## 5.6 Mains connection

### ⚠ **DANGER**



**Hazard caused by improper mains connection!**

**An improper mains connection can cause injuries or damage property!**

- Only use machine with a plug socket that has a correctly fitted protective conductor.
- If a mains plug must be fitted, this may only be carried out by an electrician in accordance with the relevant national provisions or regulations!
- Mains plug, socket and lead must be checked regularly by an electrician!
- When operating the generator always ensure it is earthed as stated in the operating instructions. The resulting network has to be suitable for operating devices according to protection class 1.

### 5.6.1 Mains configuration

*The machine may only be connected to a one-phase system with two conductors and an earthed neutral conductor.*

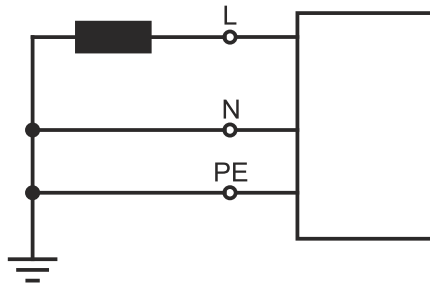

Figure 5-5

**Legend**

Item	Designation	Colour code
L	Outer conductor	brown
N	Neutral conductor	blue
PE	Protective conductor	green-yellow

### CAUTION



**Operating voltage - mains voltage!**

**The operating voltage shown on the rating plate must be consistent with the mains voltage, in order to avoid damage to the machine!**

- - See 8 Technical data chapter!

- Insert mains plug of the switched-off machine into the appropriate socket.

## 5.7 MMA welding

### CAUTION



**Risk of being crushed or burnt.**

**When replacing spent or new stick electrodes**

- Switch off machine at the main switch
- Wear appropriate safety gloves
- Use insulated tongs to remove spent stick electrodes or to move welded workpieces and
- Always put the electrode holder down on an insulated surface.

### 5.7.1 Connecting the electrode holder and workpiece lead



*Polarity depends on the instructions from the electrode manufacturer given on the electrode packaging.*

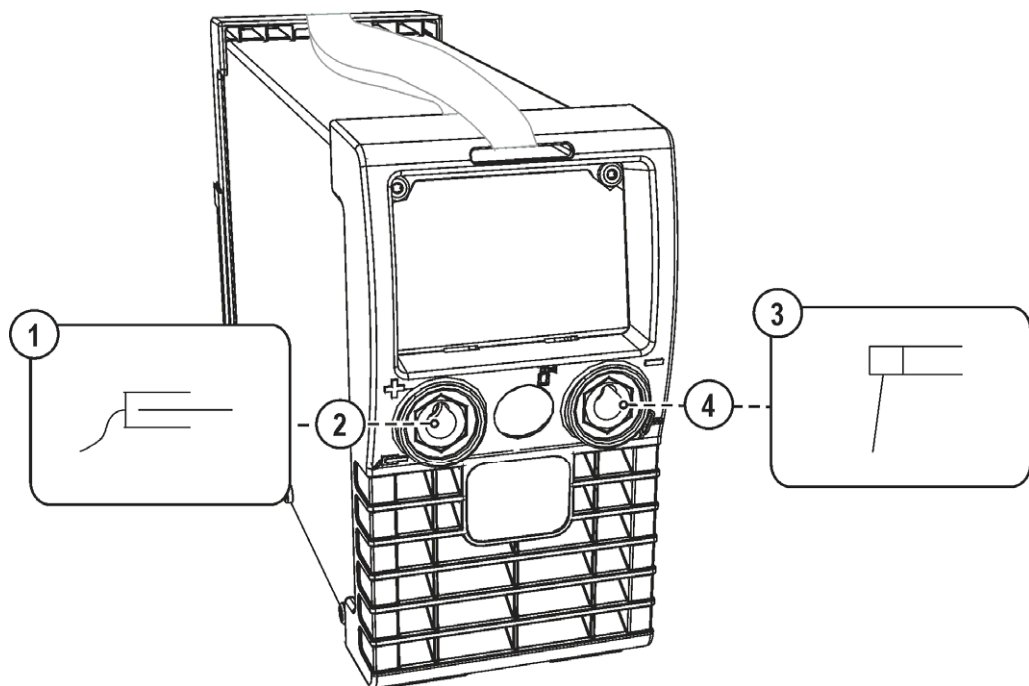

Figure 5-6

Item	Symbol	Description
1		<b>Workpiece</b>
2		<b>Connection socket for "+" welding current</b> Electrode holder or workpiece lead connection
3		<b>Electrode holder</b>
4		<b>Connection socket, "-" welding current</b> Workpiece lead or electrode holder connection

- Insert cable plug of the electrode holder into either the "+" or "-" welding current connection socket and lock by turning to the right.
- Insert cable plug of the workpiece lead into either the "+" or "-" welding current connection socket and lock by turning to the right.

## 5.7.2 Selecting MMA welding

Operating element	Action	Result
		MMA welding signal light illuminated
		Main current setting

## 5.7.3 Hotstart current and Hotstart time

The hotstart device uses an increased ignition current to improve arc ignition. The parameters for the hotstart current and time can be adjusted individually.

When the stick electrode has been struck, the arc ignites at the adjusted hotstart current AMP% (factory setting: 120 % of main current) and welds at this current until the hotstart time in seconds has elapsed (factory setting: 1 second). The hotstart current then reduces to the main current set.

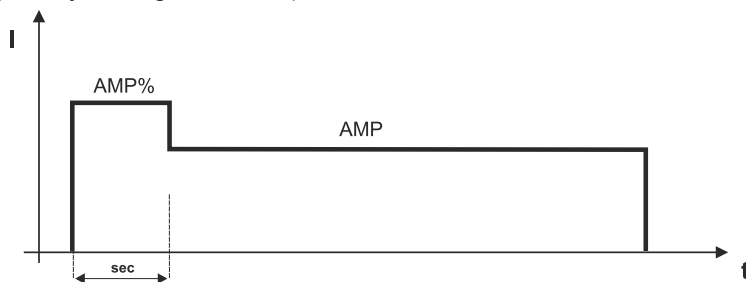

Symbol	Meaning
AMP	Main current
AMP%	Hotstart current
sec	Hotstart time

Figure 5-7

### Hotstart current

Control element	Action	Result
		Signal light AMP% lights up
		Hotstart current is set as a percentage of the main current (50 % to 200 %)

### Hotstart time

Control element	Action	Result
		Signal light sec lights up
		Hotstart time is set (0.1 s to 20 s)



After a waiting time of approx 5 seconds, the display changes back to the main current set and the signal light sec comes on.



## 5.7.4 Antistick

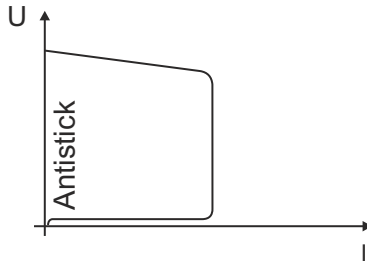

### Anti-stick prevents the electrode from annealing.

If the electrode sticks in spite of the Arcforce device, the machine automatically switches over to the minimum current within about 1 second to prevent the electrode from overheating. Check the welding current setting and correct according to the welding task!

Figure 5-8

## 5.7.5 Average value pulse welding

Average value pulse welding means that two currents are switched periodically, a current average value (AMP), a pulse current ( $I_{puls}$ ), a balance ( $bAL$ ) and a frequency ( $FrE$ ) having been defined first. The predefined ampere current average value is decisive, the pulse current ( $I_{puls}$ ) is defined by the  $IP1$  parameter as a percentage of the current average value (AMP). The pulse pause current (IPP) requires no setting. This value is calculated by the machine control, so that the welding current average value (AMP) is maintained at all times.

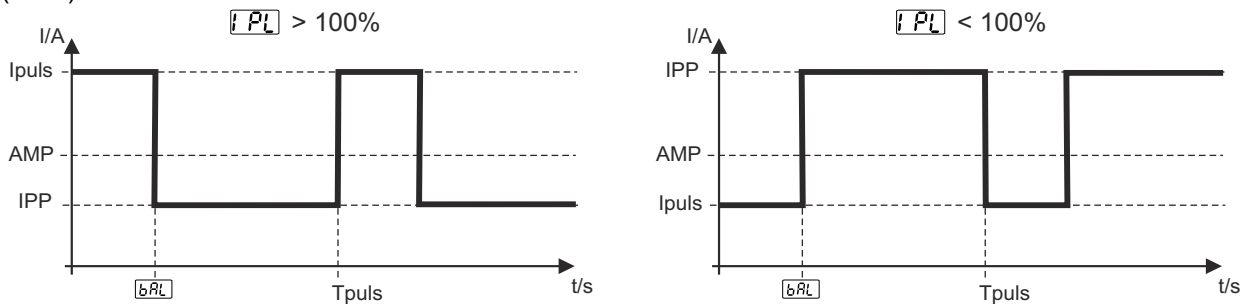

Figure 5-9

AMP = Main current; e.g. 100 A

$I_{puls}$  = Pulse current =  $IP1 \times AMP$ ; e.g. 170% x 100 A = 170 A

IPP = Pulse pause current

$T_{puls}$  = Duration of one pulse cycle =  $1/FrE$ ; e.g.  $1/1 \text{ Hz} = 1 \text{ s}$

$bAL$  = Balance =  $bAL \times T_{puls}$ ; e.g. 30% x 1 s = 0.3 s

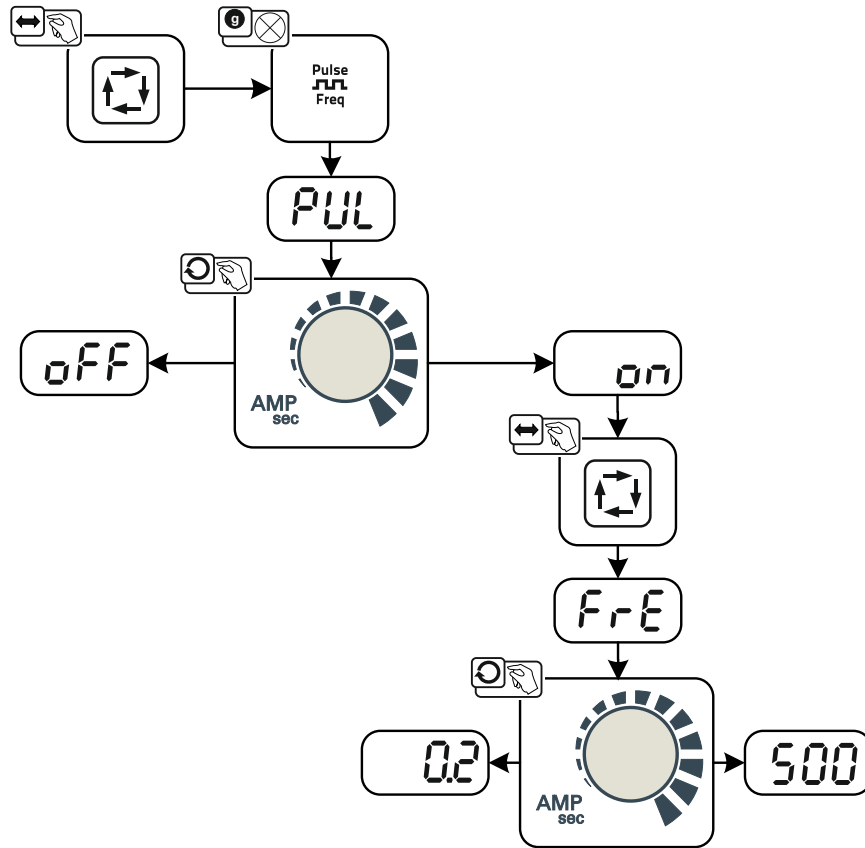

Figure 5-10

Display	Setting/selection
<b>PUL</b>	<b>Pulse welding (average value pulses)</b> <input type="checkbox"/> <b>on</b> = Function switched on <input type="checkbox"/> <b>off</b> = Function switched off (ex works)
<b>FrE</b>	<b>Pulse frequency</b> Setting range 0.2 Hz to 500 Hz, 1.2 Hz ex works.

For parameter setting, - See 5.7.6 Expert menu (MMA) chapter.

## 5.7.6 Expert menu (MMA)

The expert menu includes functions and parameters which are either not set on the machine control, or which do not require regular setting.

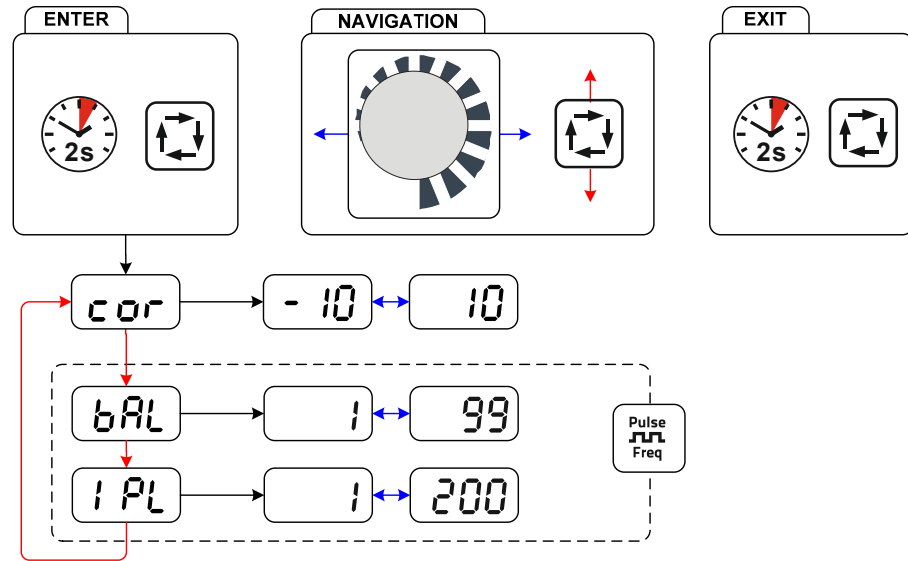

Figure 5-11

Display	Setting/selection
	<b>Arcforce correction (setting -10 to 10, factory setting 0)</b> <ul style="list-style-type: none"> <li>• Increase value &gt; harder arc</li> <li>• Decrease value &gt; softer arc</li> </ul>
	<b>Pulse balance</b> Percentage of time from pulse cycle $T_{puls}$ for pulse current Setting range 1% to 99%, ex works: 30%
	<b>Pulse current</b> Setting range 1% to 200%, ex works: 142%

## 5.8 TIG welding

### 5.8.1 Shielding gas supply (shielding gas cylinder for welding machine)

#### WARNING



**Risk of injury due to improper handling of shielding gas cylinders! Improper handling and insufficient securing of shielding gas cylinders can cause serious injuries!**

- The fastening elements must tightly enclose the shielding gas cylinder!
- Attach the fastening elements within the upper half of the shielding gas cylinder!
- Do not attach any element to the shielding gas cylinder valve!
- Observe the instructions from the gas manufacturer and any relevant regulations concerning the use of compressed air!
- Avoid heating the shielding gas cylinder!

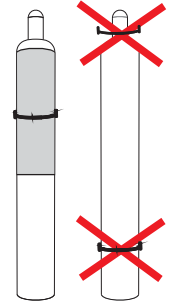

#### CAUTION



**Faults in the shielding gas supply.**

**An unhindered shielding gas supply from the shielding gas cylinder to the welding torch is a fundamental requirement for optimum welding results. In addition, a blocked shielding gas supply may result in the welding torch being destroyed.**

- Always re-fit the yellow protective cap when not using the shielding gas connection.
- All shielding gas connections must be gas tight.



***Before connecting the pressure regulator to the gas cylinder, open the cylinder valve briefly to expel any dirt.***

### 5.8.1.1 Connecting the shielding gas supply

- Secure the shielding gas cylinder using a securing chain.

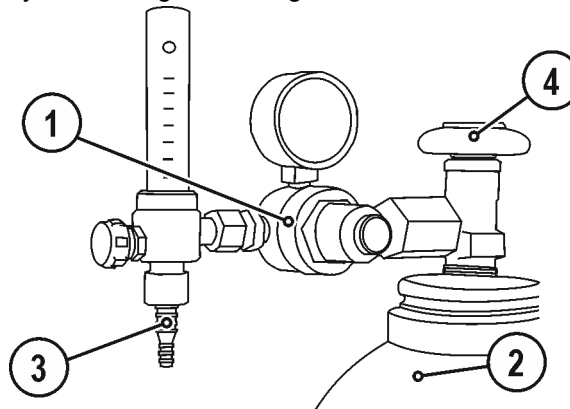

Figure 5-12

Item	Symbol	Description
1		Pressure regulator
2		Shielding gas cylinder
3		Output side of the pressure regulator
4		Cylinder valve

- Tighten the pressure regulator screw connection on the gas bottle valve to be gas-tight.
- Screw the shielding gas connection of the welding torch to the pressure reducer on the shielding gas cylinder.
- Slowly open the gas cylinder valve.
- Open the rotating valve on the welding torch

**Before each welding process, the rotating valve must be opened; after the welding process, it must be closed.**

- Set the required amount of shielding gas on the pressure reducer, about 4 - 15 l/min depending on the current strength and the material.

#### **Incorrect shielding gas setting!**

- If the shielding gas setting is too low or too high, this can introduce air to the weld pool and may cause pores to form.*
- Adjust the shielding gas quantity to suit the welding task!*

#### **Rule of thumb for the gas flow rate:**

*Diameter of gas nozzle in mm corresponds to gas flow in l/min.*

*Example: 7mm gas nozzle corresponds to 7l/min gas flow.*

## 5.8.2 Connecting a TIG welding torch with rotating gas valve

 Prepare welding torch according to the welding task in hand (see operating instructions for the torch).

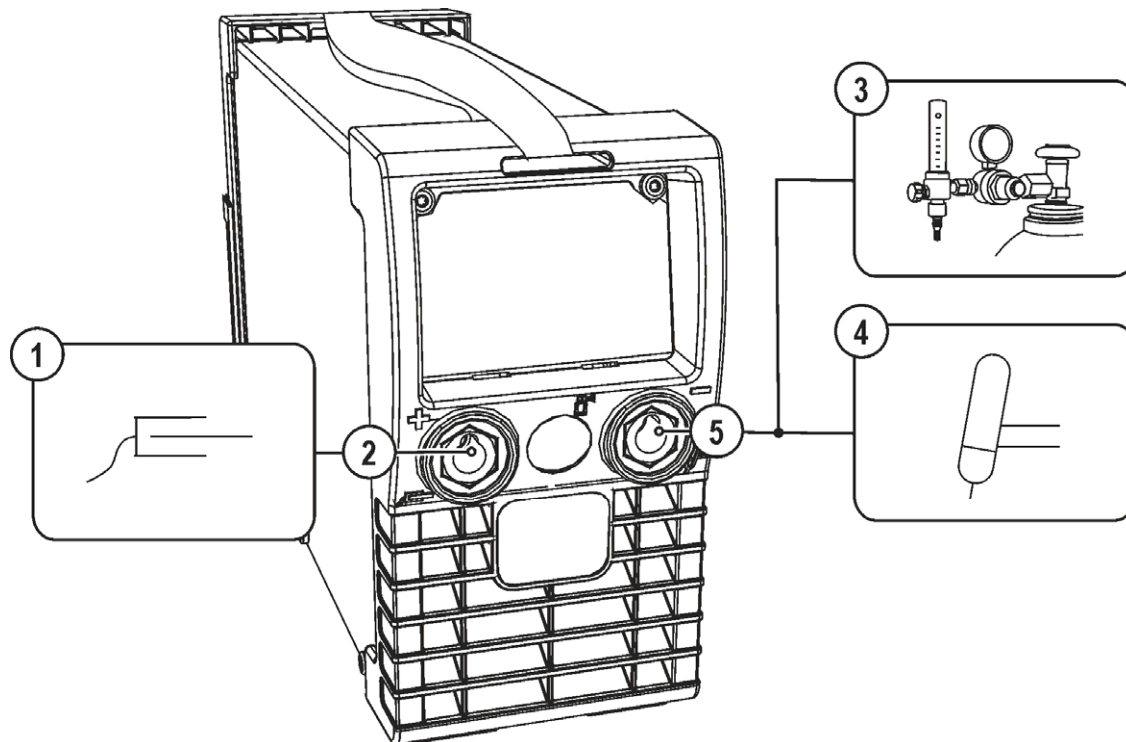





Figure 5-13

Item	Symbol	Description
1		Workpiece
2		Connection socket for "+" welding current Workpiece lead connection
3		Output side of the pressure regulator
4		Welding torch
5		Connection socket, "-" welding current Welding current lead connection for TIG welding torch

- Insert the welding current plug on the welding torch into the welding current connection socket and lock by turning to the right.
- Insert the cable plug on the work piece lead into the "+" welding current connection socket and lock by turning to the right.
- Screw the shielding gas connection of the welding torch to the pressure reducer on the shielding gas cylinder.

### 5.8.3 TIG welding selection

Control element	Action	Result
	x x	TIG welding signal light  lights up
		Main current setting

### 5.8.4 TIG arc ignition

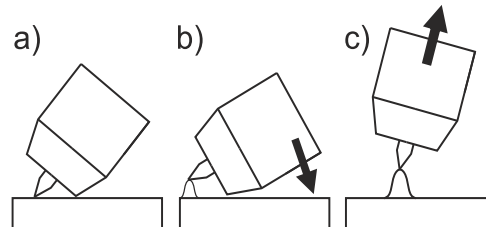

Figure 5-14

**The arc is ignited on contact with the workpiece:**

- Carefully place the torch gas nozzle and tungsten electrode tip onto the workpiece (liftarc current flowing, regardless of the main current set).
- Incline the torch towards the torch gas nozzle until there is a gap of approx. 2-3mm between the tip of the electrode and the workpiece (arc ignites, current increases to the main current set).
- Lift off the torch and swivel to the normal position.

**Ending the welding process: Remove the torch from the workpiece until the arc goes out.**

**If an RTF 1 foot-operated remote control is connected, the start procedure is initiated by pressing the foot switch.**

### 5.8.5 Average value pulse welding

Average value pulse welding means that two currents are switched periodically, a current average value (AMP), a pulse current ( $I_{puls}$ ), a balance ( $bAL$ ) and a frequency ( $FrE$ ) having been defined first. The predefined ampere current average value is decisive, the pulse current ( $I_{puls}$ ) is defined by the  $IP1$  parameter as a percentage of the current average value (AMP). The pulse pause current (IPP) requires no setting. This value is calculated by the machine control, so that the welding current average value (AMP) is maintained at all times.

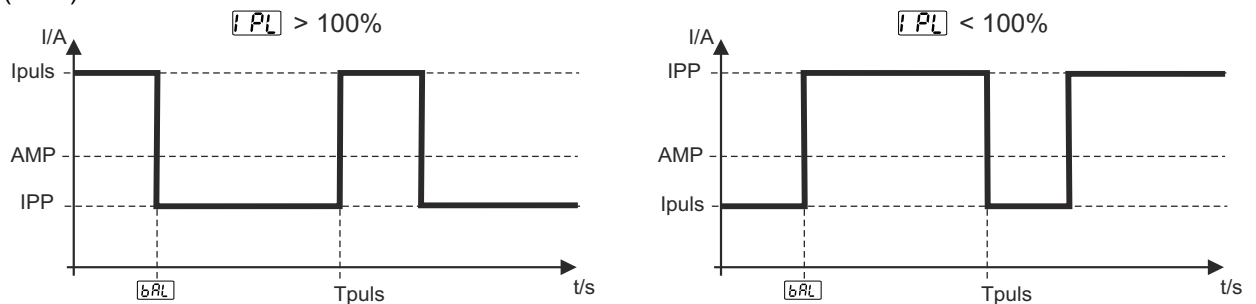

Figure 5-15

AMP = Main current; e.g. 100 A

$IPL = \text{Pulse current} = IP1 \times \text{AMP}$ ; e.g.  $170\% \times 100 \text{ A} = 170 \text{ A}$

IPP = Pulse pause current

$Tpuls = \text{Duration of one pulse cycle} = 1/FrE$ ; e.g.  $1/1 \text{ Hz} = 1 \text{ s}$

$bAL = \text{Balance} = bAL \times Tpuls$ ; e.g.  $30\% \times 1 \text{ s} = 0.3 \text{ s}$

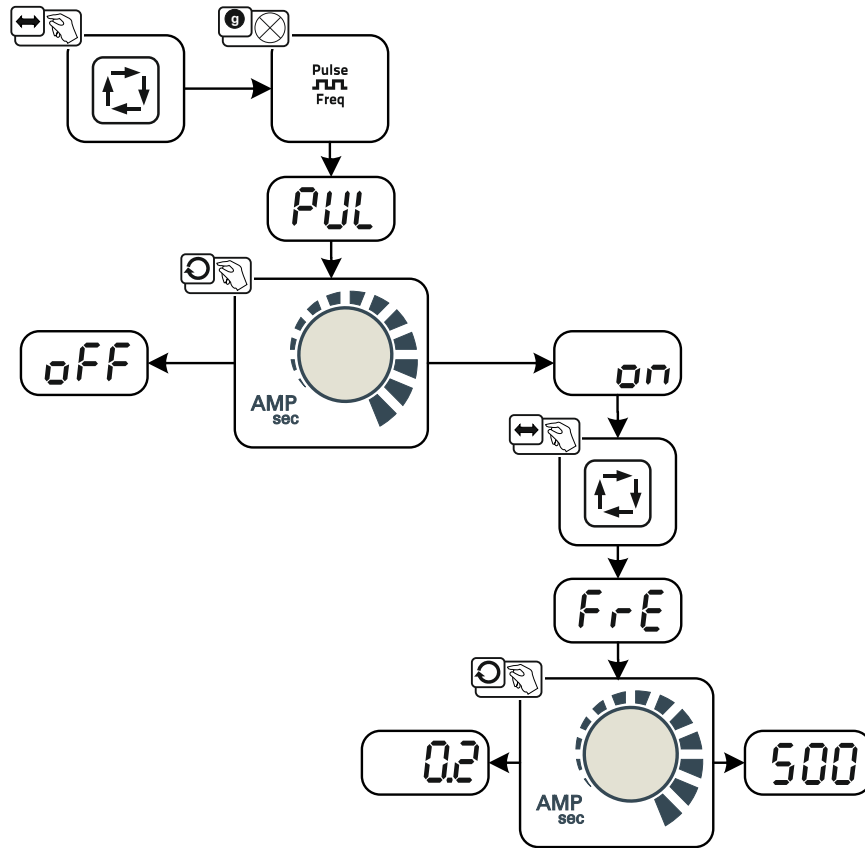

Figure 5-16

Display	Setting/selection
<b>PUL</b>	<b>Pulse welding (average value pulses)</b> <input type="checkbox"/> <b>on</b> = Function switched on <input type="checkbox"/> <b>off</b> = Function switched off (ex works)
<b>FrE</b>	<b>Pulse frequency</b> Setting range: 0.2 Hz to 2.0 kHz, ex works: 2.8 Hz

For parameter setting, - See 5.8.6 Expert menu (TIG) chapter.



## 5.8.6 Expert menu (TIG)

To change the advanced setting parameters, hold down the "Welding parameters" button for 2 seconds after selecting the welding process.  
The following diagram shows the setting options.

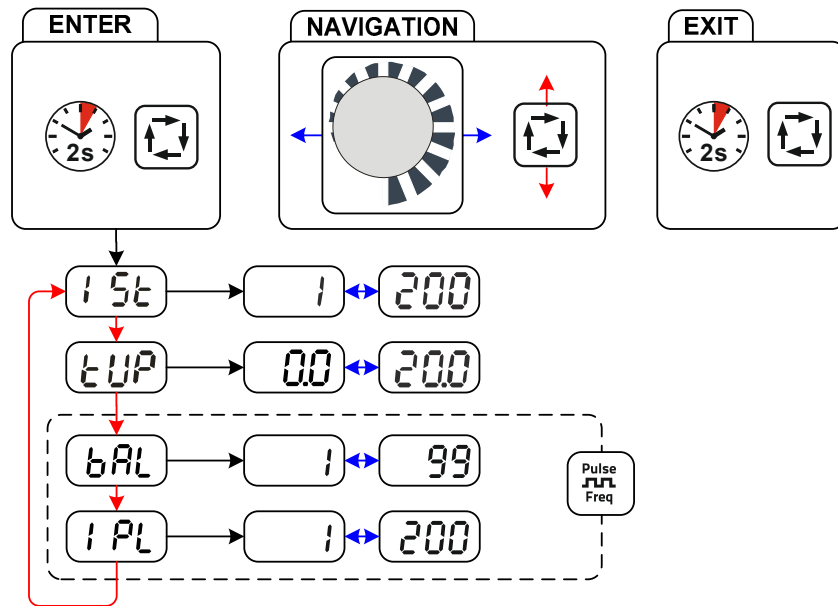

Figure 5-17

Display	Setting/selection
	<b>Ignition current</b> Setting: 1% to 200% of main current AMP (depending on main current)
	<b>Upslope time to main current</b> Setting: 0.0 sec. to 20.0 sec. (factory setting 1.0 sec.)
	<b>Pulse balance</b> Percentage of time from pulse cycle Tpuls for pulse current Setting range 1% to 99%, ex works: 50%
	<b>Pulse current</b> Setting range 1% to 200%, ex works: 140%

### 5.9 Dirt filter

- These accessory components can be retrofitted as an option - See 9 Accessories chapter.*
- The dirt filter can be used in places with unusually high levels of dirt and dust in the ambient air. The filter reduces the duty cycle of the welding machine via the reduced flow of cooling air. The filter must be disassembled and cleaned regularly depending on the level of dirt (blow out with compressed air).*

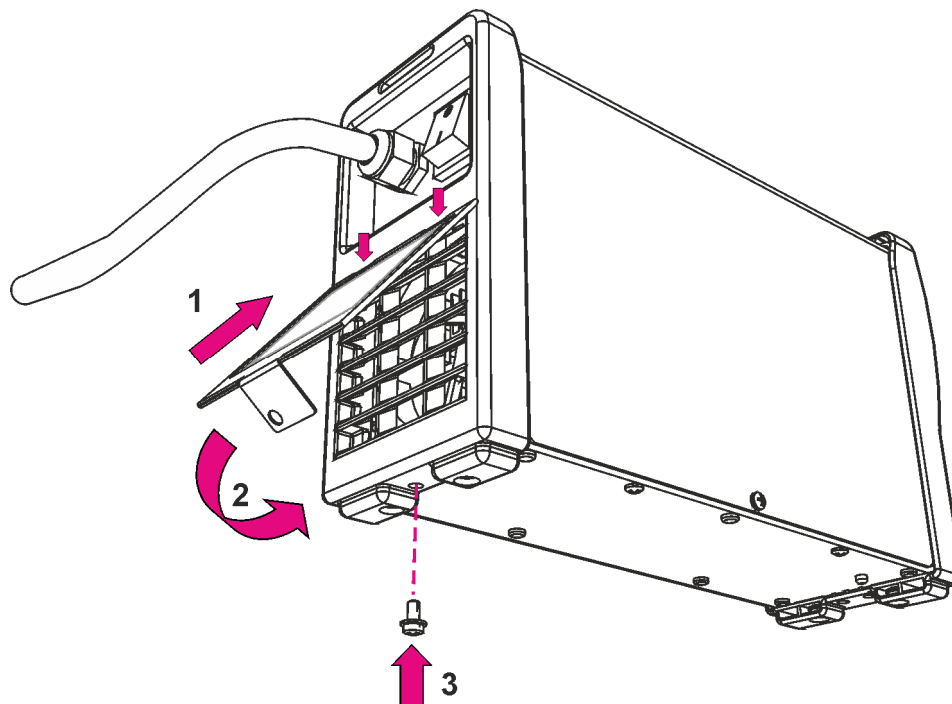

Figure 5-18

- As shown in the diagram, insert the dirt filter into the rear of the machine, above the air inlet, using both clips (1).
- Fold down the dirt filter (2).
- Fasten the dirt filter to the underside of the machine (3) using fixing screws.

## 5.10 Power-saving mode (Standby)

You can activate the power-saving mode by either pressing the push-button for a prolonged time or by setting a parameter in the machine configuration menu (time-controlled power-saving mode).



When power-saving mode is activated, the machine displays show the horizontal digit in the centre of the display only.

Pressing any operating element (e.g. tapping the torch trigger) deactivates power-saving mode and the machine is ready for welding again.

- See 4.3 Machine control – Operating elements chapter

- See 5.13 Machine configuration menu chapter

## 5.11 Remote control



*The remote controls are operated on the 19-pole remote control connection socket (analogue).*

### 5.11.1 RT1 19POL

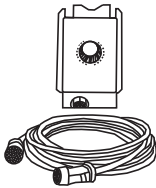

#### Functions

- Infinitely adjustable welding current (0% to 100%) depending on the preselected main current on the welding machine.

### 5.11.2 RTG1 19POL

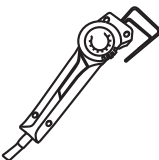

#### Functions

- Infinite setting of the welding current (0% to 100%) depending on the main current preselected at the welding machine

### 5.11.3 RTF1 19POL

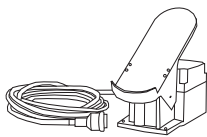

#### Functions

- Infinitely adjustable welding current (0% to 100%) depending on the preselected main current on the welding machine.
- Start/stop welding operation (TIG)

## 5.12 Voltage reducing device

The voltage reducing device is a requirement in some countries and in many internal company safety guidelines for power sources.

The voltage reduction device is only active on VRD machine versions.

To increase safety, particularly in hazardous environments (like shipbuilding, pipe construction or mining), the machine is equipped with the VRD (Voltage-reducing device) voltage reduction device.

The VRD signal light is illuminated, when the voltage reduction device is operating without fault and the output voltage is reduced to a value specified in the relevant standard (see technical data).

- See 4.3 Machine control – Operating elements chapter

- See 8 Technical data chapter

## 5.13 Machine configuration menu

### ENTER (Enter the menu)

- Switch off machine at the main switch.
- Hold down the "Welding process" button and simultaneously switch the machine on again. Wait until the "EIt" menu item is shown and release the button.

### NAVIGATION (navigating in the menu)

- Parameters are selected by pressing the "welding parameters" button.
- Set or change the parameters by turning the "welding parameter setting" rotary dial.

### EXIT (Exit the menu)

- Select the "EIt" menu item.
- Press the "Welding parameters" button (settings will be applied, machine changes to the ready-to-operate status).

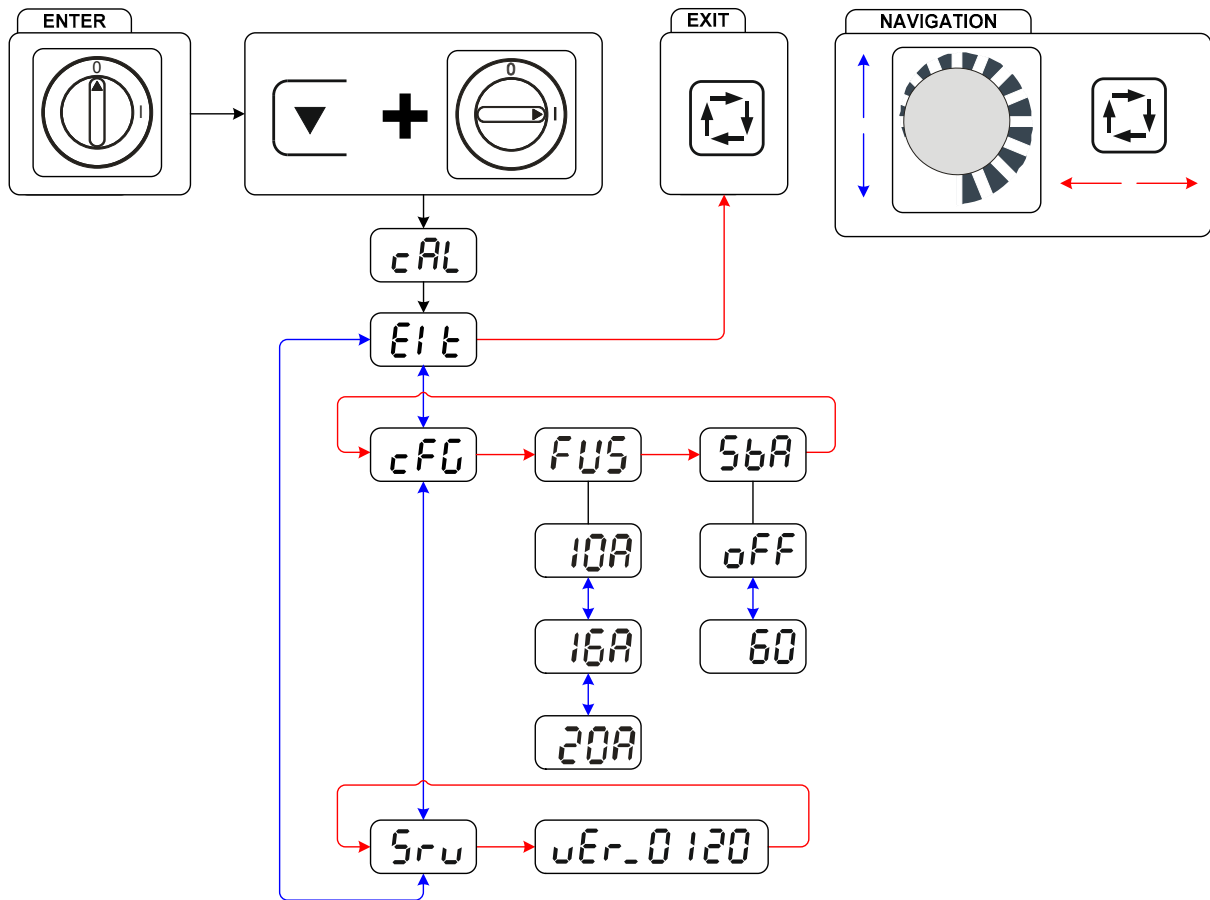

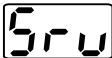



Figure 5-19

Display	Setting/selection
	<b>Calibration</b> The machine will be calibrated for approx 2 seconds each time it is switched on.
	<b>Exit the menu</b> Exit
	<b>Machine configuration</b> Settings for machine functions and parameter display
	<b>Dynamic power adjustment</b> 20 A    Setting for 20 A mains fuse protection 16 A    Setting for 16 A mains fuse protection (factory setting) 10 A    Setting for 10 A mains fuse protection

Display	Setting/selection
	<b>Time-based power-saving mode</b> <ul style="list-style-type: none"><li>• 5 min.–60 min. = Time to activation of power-saving mode in case of inactivity.</li><li>• off = inactivated (ex works)</li></ul>
	<b>Service menu</b> <p>Any changes to the service menu should be agreed with the authorised service personnel.</p>
	<b>Software version of the machine control</b> <p>Version display</p>

## 6 Maintenance, care and disposal



### Improper maintenance and testing

The equipment may only be cleaned, repaired or tested by specialist, skilled persons! A skilled person is one who, due to training, knowledge and experience, is able to recognise the dangers that can occur during testing of this equipment as well as possible subsequent damage and who is able to implement the required safety procedures.

- Complete all tests given in the chapter below!
- Only put the equipment back into operation following a successful test.



### Risk of injury from electric shock!

**Cleaning machines that are not disconnected from the mains can lead to serious injuries!**

- Disconnect the machine completely from the mains.
- Remove the mains plug!
- Wait for 4 minutes until the capacitors have discharged!

Repair and maintenance work may only be performed by qualified authorised personnel; otherwise the right to claim under warranty is void. In all service matters, always consult the dealer who supplied the machine. Return deliveries of defective equipment subject to warranty may only be made through your dealer. When replacing parts, use only original spare parts. When ordering spare parts, please quote the machine type, serial number and item number of the machine, as well as the type designation and item number of the spare part.

### 6.1 General

When used in the specified environmental conditions and under normal operating conditions, this machine is largely maintenance-free and requires a minimum of care.

There are some points, which should be observed, to guarantee fault-free operation of your welding machine. Among these are regular cleaning and checking as described below, depending on the pollution level of the environment and the length of time the unit is in use.

### 6.2 Maintenance work, intervals

#### 6.2.1 Daily maintenance tasks

##### 6.2.1.1 Visual inspection

- Mains supply lead and its strain relief
- Gas tubes and their switching equipment (solenoid valve)
- Other, general condition

##### 6.2.1.2 Functional test

- Welding current cables (check that they are fitted correctly and secured)
- Gas cylinder securing elements
- Operating, message, safety and adjustment devices (Functional test)

#### 6.2.2 Monthly maintenance tasks

##### 6.2.2.1 Visual inspection

- Casing damage (front, rear and side walls)
- Transport elements (strap, lifting lugs, handle)

##### 6.2.2.2 Functional test

- Selector switches, command devices, emergency stop devices, voltage reducing devices, message and control lamps

### 6.2.3 Annual test (inspection and testing during operation)

 **The welding machine may only be tested by competent, capable persons!** A capable person is one who, because of his training, knowledge and experience, is able to recognise the dangers that can occur while testing welding power sources as well as possible subsequent damage and who is able to implement the required safety procedures.

 **For more information refer to the "Warranty registration" brochure supplied and our information regarding warranty, maintenance and testing at [www.ewm-group.com](http://www.ewm-group.com)!**

A periodic test according to IEC 60974-4 "Periodic inspection and test" has to be carried out. In addition to the regulations on testing given here, the relevant local laws and regulations must also be observed.

## 6.3 Disposing of equipment

 **Proper disposal!**

**The machine contains valuable raw materials, which should be recycled, and electronic components, which must be disposed of.**

- **Do not dispose of in household waste!**
- **Observe the local regulations regarding disposal!**



### 6.3.1 Manufacturer's declaration to the end user

- According to European provisions (guideline 2002/96/EG of the European Parliament and the Council of January, 27th 2003), used electric and electronic equipment may no longer be placed in unsorted municipal waste. It must be collected separately. The symbol depicting a waste container on wheels indicates that the equipment must be collected separately.  
This machine is to be placed for disposal or recycling in the waste separation systems provided for this purpose.
- According to German law (law governing the distribution, taking back and environmentally correct disposal of electric and electronic equipment (ElektroG) from 16.03.2005), used machines are to be placed in a collection system separate from unsorted municipal waste. The public waste management utilities (communities) have created collection points at which used equipment from private households can be disposed of free of charge.
- Information about giving back used equipment or about collections can be obtained from the respective municipal administration office.
- EWM participates in an approved waste disposal and recycling system and is registered in the Used Electrical Equipment Register (EAR) under number WEEE DE 57686922.
- In addition to this, returns are also possible throughout Europe via EWM sales partners.

## 6.4 Meeting the requirements of RoHS

We, EWM AG Mündersbach, hereby confirm that all products supplied by us which are affected by the RoHS Directive, meet the requirements of the RoHS (Directive 2011/65/EU).

## 7 Rectifying faults

All products are subject to rigorous production checks and final checks. If, despite this, something fails to work at any time, please check the product using the following flowchart. If none of the fault rectification procedures described leads to the correct functioning of the product, please inform your authorised dealer.

### 7.1 Checklist for rectifying faults



**The correct machine equipment for the material and process gas in use is a fundamental requirement for perfect operation!**

Legend	Symbol	Description
	↘	Fault/Cause
	✘	Remedy

#### Excess temperature signal light illuminates

- ↘ Excess temperature, welding machine
- ✘ Allow the machine to cool down whilst still switched on

#### Functional errors

- ↘ Machine control without displaying the signal lights after switching on
  - ✘ Phase failure > check mains connection (fuses)
- ↘ Connection problems
  - ✘ Make control lead connections and check that they are fitted correctly.
- ↘ Loose welding current connections
  - ✘ Tighten power connections on the torch and/or on the workpiece
  - ✘ Tighten contact tip correctly



## 7.2 Machine faults (error messages)

 **A welding machine error is indicated by an error code being displayed (see table) on the display on the machine control.**

**In the event of a machine error, the power unit is shut down.**

 **The display of possible error numbers depends on the machine version (interfaces/functions).**

- If multiple errors occur, these are displayed in succession.
- Document machine errors and inform service staff as necessary.

Error message	Possible cause	Remedy
E 0	Start signal set in the event of errors	Do not press the torch trigger or the foot-operated remote control
E 4	Temperature error	Allow the machine to cool down
E 5	Mains overvoltage	Switch off the machine and check the mains voltage
E 6	Mains undervoltage	
E 7	Electronics error	Switch the machine on and off again.
E 9	Secondary overvoltage	If the error persists, notify service department
E12	Voltage reduction error (VRD)	
E13	Electronics error	
E14	Adjustment error in current recording	
E15	Error in one of the electronics supply voltages	Switch the machine off and on again. If the error persists, notify service department
E23	Temperature error	Allow the machine to cool down
E32	Electronics error	Switch the machine on and off again. If the error persists, notify service department
E33	Adjustment error in voltage recording	Switch off the machine, place the electrode holder in an insulated position and switch the machine back on. If the error persists, notify service department
E34	Electronics error	Switch the machine on and off again. If the error persists, notify service department
E37	Temperature error	Allow the machine to cool down
E40	Motor fault	Check wire feed unit, switch the machine off and on again, inform the service department if the fault persists.
E55	Failure of a mains phase	Switch off the machine and check the mains voltage
E58	Short circuit in welding circuit	Switch off machine and check welding current leads for correct installation, e.g., put down electrode holder in an electrically insulated manner, disconnect degausser current lead.

## 7.3 Display machine control software version

*The query of the software versions only serves to inform the authorised service staff. It is available in the machine configuration menu.*

## 7.4 Dynamic power adjustment

*This requires use of the appropriate mains fuse. Observe mains fuse specification- See 8 Technical data chapter!*

The dynamic power adjustment automatically adjusts the welding performance to an uncritical level for the fuse.

There are three performance settings for the dynamic power adjustment in the advanced settings



(Parameter **FUS**): 20 A, 16 A, 10 A- See 5.13 Machine configuration menu chapter.

The currently selected value will be shown on the **cAL** section of the display for three seconds after the machine has been switched on.

## 7.5 Resetting welding parameters to the factory settings

*All customised welding parameters that are stored will be replaced by the factory settings.*

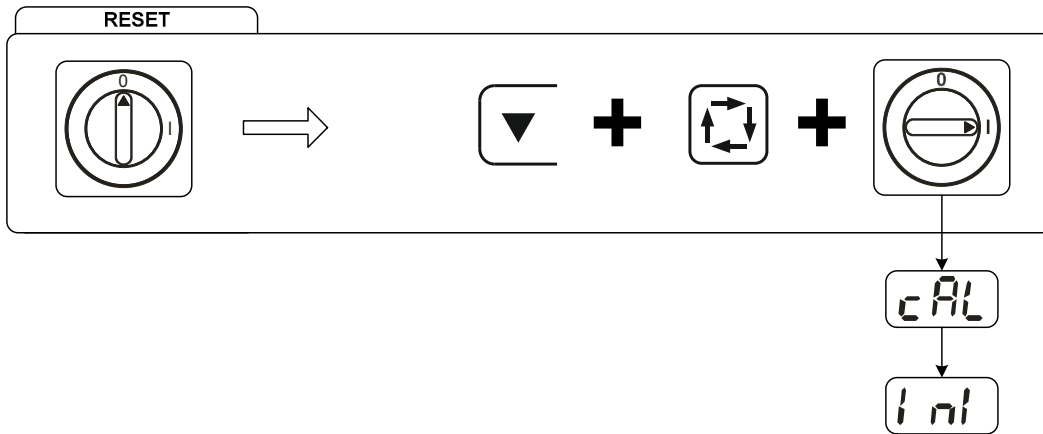

Figure 7-1

Display	Setting/selection
	<b>Calibration</b> The machine will be calibrated for approx 2 seconds each time it is switched on.
	<b>Initialising</b> Keep the push-button pressed until "InI" is shown on the display.

## 8 Technical data

 *Performance specifications and guarantee only in connection with original spare and replacement parts!*

### 8.1 Pico 180

	TIG	MMA
Setting range for welding current	5 A–180 A	5 A–180 A
Setting range for welding voltage	10.2 V–17.2 V	20.2 V–27.2 V
Duty cycle (DC) at 25 °C		
30%	-	180 A
35%	180 A	-
60%	160 A	140 A
100%	150 A	130 A
Duty cycle (DC) at 40 °C		
25%	-	180 A
30%	180 A	-
60%	150 A	130 A
100%	130 A	120 A
Load cycle	10 min. (60% DC $\pm$ 6 min. welding, 4 min. pause)	
Open circuit voltage	98 V	
Reduced	12 V	-
Reduced, VRD variant	12 V	33 V
Reduced, VRD 12V variant	12 V	
Mains voltage (tolerances)	1 x 230 V (-40% to +15%)	
Frequency	50/60 Hz	
Mains fuse (safety fuse, slow-blow)	1 x 20 A	
Mains connection lead	H07RN-F3G2,5	
Max. connected load	4.4 kVA	6.9 kVA
Recommended generator rating	9.3 kVA	
cos $\phi$ /efficiency	0.99/86%	
Insulation class/protection classification	H/IP 23	
Ambient temperature	-25 °C to +40 °C	
Machine cooling	Fan	
Workpiece lead	35 mm <sup>2</sup>	
Dimensions L x W x H in mm	470 x 135 x 250	
Weight	8.9 kg	
EMC class	A	
Constructed to standard	IEC 60974-1, -10 ☐; CE	
VRD variant	AS 1674.2-2003	
VRD 12V variant	ГОСТ 12.2 007.8	

## 9 Accessories



*Performance-dependent accessories like torches, workpiece leads, electrode holders or intermediate hose packages are available from your authorised dealer.*

### 9.1 Transport systems

Type	Designation	Item no.
Trolly 35-1	Transport vehicle	090-008629-00000

### 9.2 Remote controls and accessories

Type	Designation	Item no.
RT1 19POL	Remote control current	090-008097-00000
RA5 19POL 5M	Remote control e.g. connection cable	092-001470-00005
RA10 19POL 10M	Remote control e.g. connection cable	092-001470-00010
RA20 19POL 20M	Remote control e.g. connection cable	092-001470-00020
RTF1 19POL 5 M	Foot-operated remote control current with connection cable	094-006680-00000
RV5M19 19POLE 5M	Extension cable	092-000857-00000

### 9.3 General accessories

Type	Designation	Item no.
DMDIN TN 200B AR/MIX 35L	Manometer pressure regulator	094-000009-00000
GH 2X1/4" 2M	Gas hose	094-000010-00001
ON Filter Pico/Picotig 180/200	Dirt filter for air inlet	092-002546-00000
ADAP CEE16/SCHUKO	Earth contact coupling/CEE16A plug	092-000812-00000

## 10 Appendix A

### 10.1 Overview of EWM branches

#### Headquarters

**EWM AG**  
Dr. Günter-Henle-Straße 8  
56271 Mündersbach · Germany  
Tel: +49 2680 181-0 · Fax: -244  
www.ewm-group.com · info@ewm-group.com

#### Technology centre

**EWM AG**  
Forststraße 7-13  
56271 Mündersbach · Germany  
Tel: +49 2680 181-0 · Fax: -144  
www.ewm-group.com · info@ewm-group.com



#### Production, Sales and Service

**EWM AG**  
Dr. Günter-Henle-Straße 8  
56271 Mündersbach · Germany  
Tel: +49 2680 181-0 · Fax: -244  
www.ewm-group.com · info@ewm-group.com

**EWM HIGH TECHNOLOGY (Kunshan) Ltd.**  
10 Yuanshan Road, Kunshan · New & Hi-tech Industry Development Zone  
Kunshan City · Jiangsu · Post code 215300 · People's Republic of China  
Tel: +86 512 57867-188 · Fax: -182  
www.ewm.cn · info@ewm.cn · info@ewm-group.cn

**EWM HIGHTEC WELDING s.r.o.**  
9. května 718 / 31  
407 53 Jiríkov · Czech Republic  
Tel.: +420 412 358-551 · Fax: -504  
www.ewm-jiríkov.cz · info@ewm-jiríkov.cz

#### Sales and Service Germany

**EWM AG**  
Sales and Technology Centre  
Grünauer Fenn 4  
14712 Rathenow · Tel: +49 3385 49402-0 · Fax: -20  
www.ewm-rathenow.de · info@ewm-rathenow.de

**EWM AG**  
Rudolf-Winkel-Straße 7-9  
37079 Göttingen · Tel: +49 551-3070713-0 · Fax: -20  
www.ewm-goettingen.de · info@ewm-goettingen.de

**EWM AG**  
Sachsstraße 28  
50259 Pulheim · Tel: +49 2234 697-047 · Fax: -048  
www.ewm-pulheim.de · info@ewm-pulheim.de

**EWM AG**  
August-Horch-Straße 13a  
56070 Koblenz · Tel: +49 261 963754-0 · Fax: -10  
www.ewm-koblenz.de · info@ewm-koblenz.de

**EWM AG**  
Eiserfelder Straße 300  
57080 Siegen · Tel: +49 271 3878103-0 · Fax: -9  
www.ewm-siegen.de · info@ewm-siegen.de

**EWM HIGHTEC WELDING GmbH**  
Sales and Technology Centre  
Draisstraße 2a  
69469 Weinheim · Tel: +49 6201 84557-0 · Fax: -20  
www.ewm-weinheim.de · info@ewm-weinheim.de

**EWM Schweißtechnik Handels GmbH**  
Karlsdorfer Straße 43  
88069 Tettngang · Tel: +49 7542 97998-0 · Fax: -29  
www.ewm-tettngang.de · info@ewm-tettngang.de

**EWM Schweißtechnik Handels GmbH**  
Heinkelstraße 8  
89231 Neu-Ulm · Tel: +49 731 7047939-0 · Fax: -15  
www.ewm-neu-ulm.de · info@ewm-neu-ulm.de

#### Sales and Service International

**EWM HIGH TECHNOLOGY (Kunshan) Ltd.**  
10 Yuanshan Road, Kunshan · New & Hi-tech Industry Development Zone  
Kunshan City · Jiangsu · Post code 215300 · People's Republic of China  
Tel: +86 512 57867-188 · Fax: -182  
www.ewm.cn · info@ewm.cn · info@ewm-group.cn

**EWM HIGHTEC WELDING GmbH**  
Wiesenstraße 27b  
4812 Pinsdorf · Austria · Tel: +43 7612 778 02-0 · Fax: -20  
www.ewm-austria.at · info@ewm-austria.at

**EWM HIGHTEC WELDING UK Ltd.**  
Unit 2B Coopies Way · Coopies Lane Industrial Estate  
Morpeth · Northumberland · NE61 6JN · Great Britain  
Tel: +44 1670 505875 · Fax: -514305  
www.ewm-morpeth.co.uk · info@ewm-morpeth.co.uk

**EWM HIGHTEC WELDING Sales s.r.o. / Prodejní a poradenské centrum**  
Tyršova 2106  
256 01 Benešov u Prahy · Czech Republic  
Tel: +420 317 729-517 · Fax: -712  
www.ewm-benesov.cz · info@ewm-benesov.cz

#### Liaison office Turkey

**EWM AG Türkiye İrtibat Bürosu**  
İkitelli OSB Mah. · Marmara Sanayi Sitesi P Blok Apt. No: 44  
Küçükçekmece / İstanbul Türkiye  
Tel.: +90 212 494 32 19  
www.ewm-istanbul.com.tr · info@ewm-istanbul.com.tr

Plants

Branches

Liaison office

● More than 400 EWM sales partners worldwide