



EN

Retrofit option

ON 19pol F.0001/F.0002

19-pole connection socket for accessory components and/or as analogue interface

099-001951-EW501

Observe additional system documents!

04.06.2019

**Register now
and benefit!
Jetzt Registrieren
und Profitieren!**

www.ewm-group.com



General instructions

WARNING



Read the operating instructions!

The operating instructions provide an introduction to the safe use of the products.

- Read and observe the operating instructions for all system components, especially the safety instructions and warning notices!
- Observe the accident prevention regulations and any regional regulations!
- The operating instructions must be kept at the location where the machine is operated.
- Safety and warning labels on the machine indicate any possible risks. Keep these labels clean and legible at all times.
- The machine has been constructed to state-of-the-art standards in line with any applicable regulations and industrial standards. Only trained personnel may operate, service and repair the machine.
- Technical changes due to further development in machine technology may lead to a differing welding behaviour.

In the event of queries on installation, commissioning, operation or special conditions at the installation site, or on usage, please contact your sales partner or our customer service department on +49 2680 181-0.

A list of authorised sales partners can be found at www.ewm-group.com/en/specialist-dealers.

Liability relating to the operation of this equipment is restricted solely to the function of the equipment. No other form of liability, regardless of type, shall be accepted. This exclusion of liability shall be deemed accepted by the user on commissioning the equipment.

The manufacturer is unable to monitor whether or not these instructions or the conditions and methods are observed during installation, operation, usage and maintenance of the equipment.

An incorrectly performed installation can result in material damage and injure persons as a result. For this reason, we do not accept any responsibility or liability for losses, damages or costs arising from incorrect installation, improper operation or incorrect usage and maintenance or any actions connected to this in any way.

© EWM AG

Dr. Günter-Henle-Strasse 8
56271 Mündersbach Germany
Tel.: +49 2680 181-0, Fax: -244
Email: info@ewm-group.com

www.ewm-group.com

The copyright to this document remains the property of the manufacturer.

Copying, including extracts, only permitted with written approval.

The content of this document has been prepared and reviewed with all reasonable care. The information provided is subject to change; errors excepted.

1 Safety instructions**1.1 For your safety****⚠ WARNING**

Do not carry out any unauthorised repairs or modifications!

To avoid injury and equipment damage, the unit must only be repaired or modified by specialist, skilled persons!

The warranty becomes null and void in the event of unauthorised interference.

- Appoint only skilled persons for repair work (trained service personnel)!



Risk of accidents due to non-compliance with the safety instructions!

Non-compliance with the safety instructions can be fatal!

- Carefully read the safety instructions in this manual!
- Observe the accident prevention regulations and any regional regulations!
- Inform persons in the working area that they must comply with the regulations!

⚠ CAUTION

Obligations of the operator!

The respective national directives and laws must be complied with when operating the machine!

- Implementation of national legislation relating to framework directive 89/391/EEC on the introduction of measures to encourage improvements in the safety and health of workers at work and associated individual guidelines.
- In particular, directive 89/655/EEC concerning the minimum safety and health requirements for the use of work equipment by workers at work.
- The regulations applicable to occupational safety and accident prevention in the country concerned.
- Setting up and operating the machine as per IEC 60974.-9.
- Brief the user on safety-conscious work practices on a regular basis.
- Regularly inspect the machine as per IEC 60974.-4.

These supplementary sheets must be used in conjunction with the appropriate standard operating instructions for the described product! These supplementary sheets expand or replace one or more chapters of the same name(s) in the standard description.

Read and observe the operating instructions for all system components, especially the safety instructions!

2 Intended use

2.1 General

WARNING



Hazards due to improper usage!

The machine has been constructed to the state of the art and any regulations and standards applicable for use in industry and trade. It may only be used for the welding procedures indicated at the rating plate. Hazards may arise for persons, animals and material objects if the equipment is not used correctly. No liability is accepted for any damages arising from improper usage!

- The equipment must only be used in line with its designated purpose and by trained or expert personnel!
- Do not improperly modify or convert the equipment!

These instructions apply only for the conversion of the following machines:

- Tetrax 351, -401, -451, -551 DC
- Tetrax 351, -451, -551 AC/DC

2.2 Short description of the working steps required

- Installing the 19-pole connection socket in the casing back plate.
- Wiring the installed components.

3 Conversion

3.1 General

DANGER



Risk of injury from electric shock!

Servicing machines that are not disconnected from the mains can lead to serious injuries!

- Disconnect the machine completely from the mains.
Pull out the mains plug!
- Wait for 4 minutes until the capacitors have discharged!



Wiring the accessories has to follow the machine's circuit diagrams at all times!

The circuit diagrams can be found in the machine (document pouch on the casing cover) and may also be included in these conversion instructions!

3.2 Parts list

Before conversion, check that the retrofit kit is complete (see parts list).

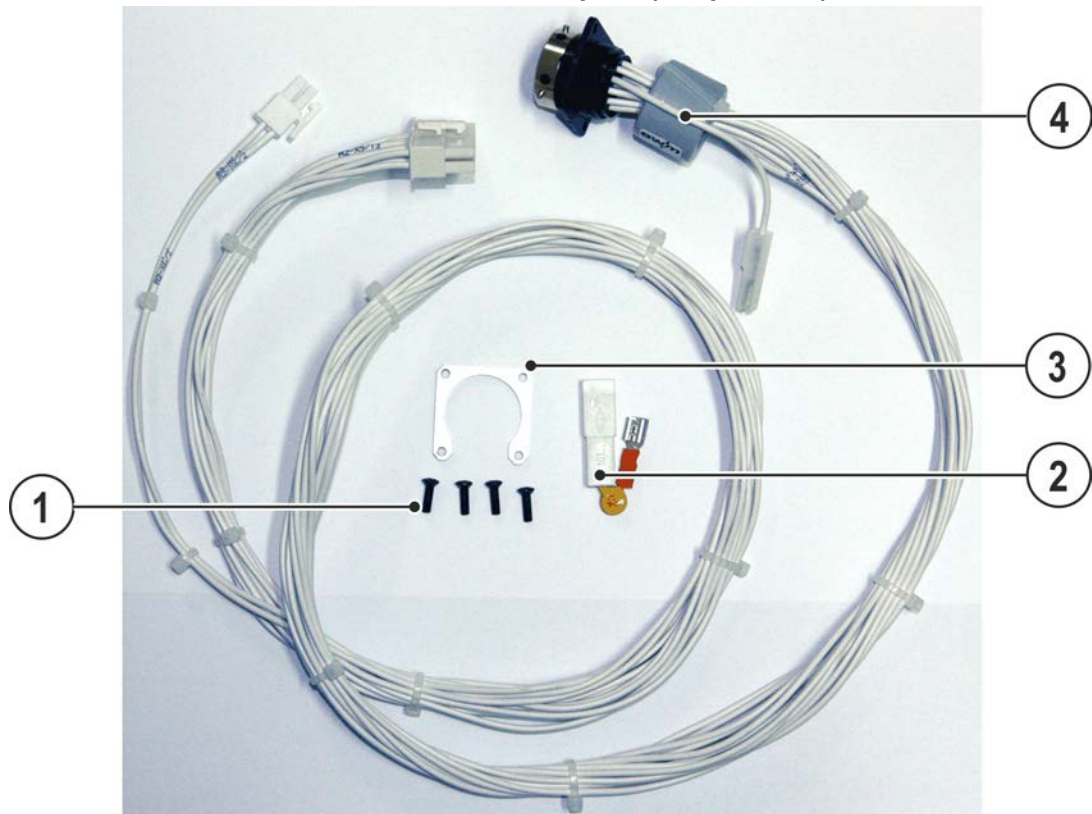

Figure 3-1

Item	Quantity	Description	Item number
1	4	Torx screw M3x10	094-023445-00000
2	1	Capacitor	092-000324-00012
3	1	Fixing plate	094-009379-00000
4	1	19-pole interface for automated welding	094-009343-00000

3.3 Preparations

WARNING



Protective earth PE!

To protect persons and animals against dangerous live voltages and electric shocks in the event of a fault, the casing panels on the unit are connected to a green/yellow protective earth.

- After conversion, re-connect the protective earth to the casing panels!

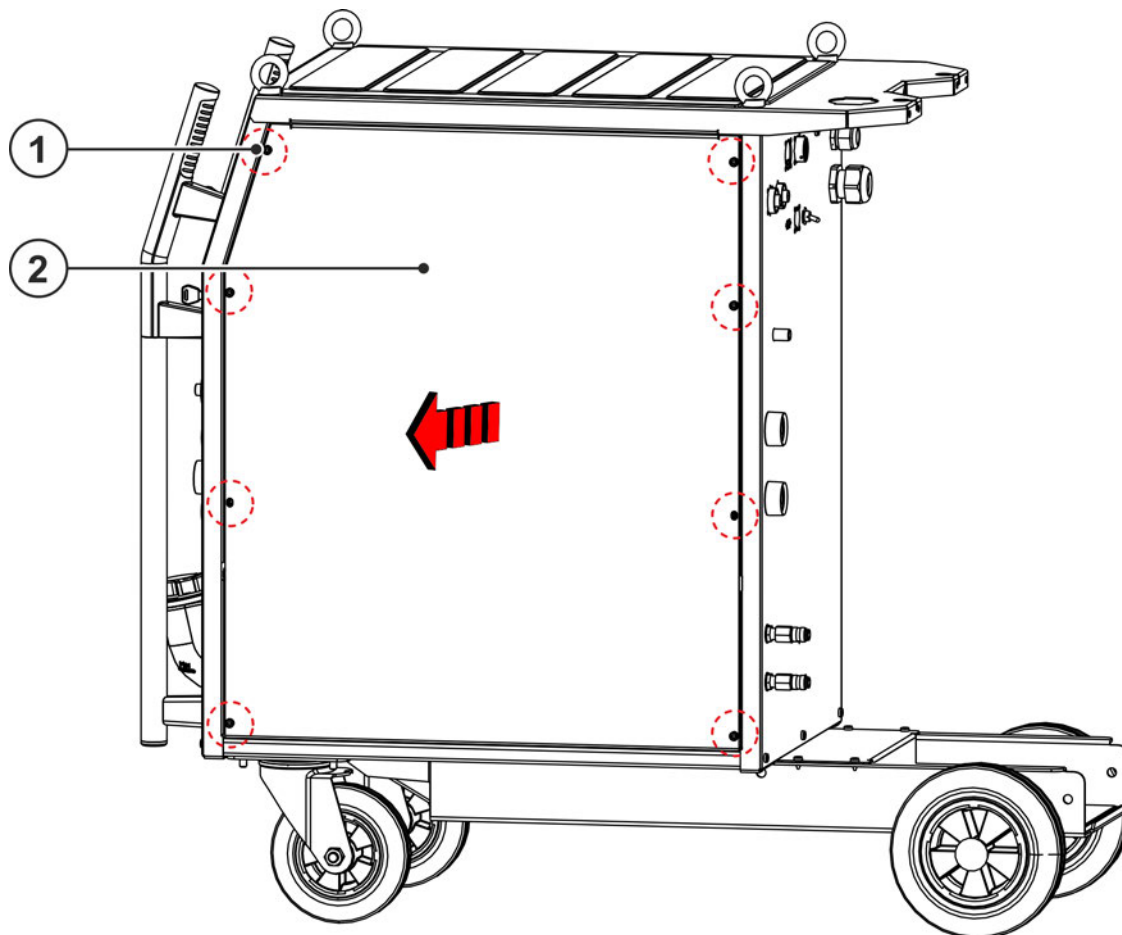

Figure 3-2

Item	Symbol	Description
1		Casing screws
2		Casing cover

- Unscrew the casing cover.
- Remove the earth cable from the cover plate.

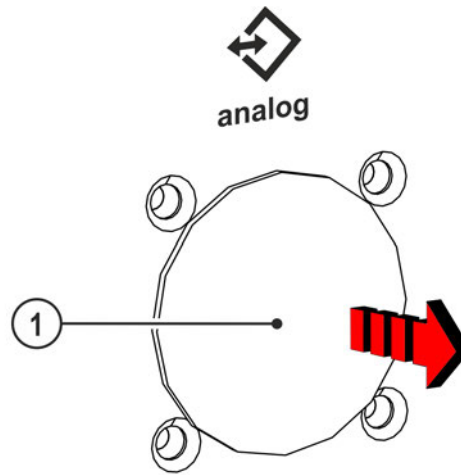

Figure 3-3

Item	Quantity	Description	Item number
1	1	Cap, wheel fastening	

- Remove cap

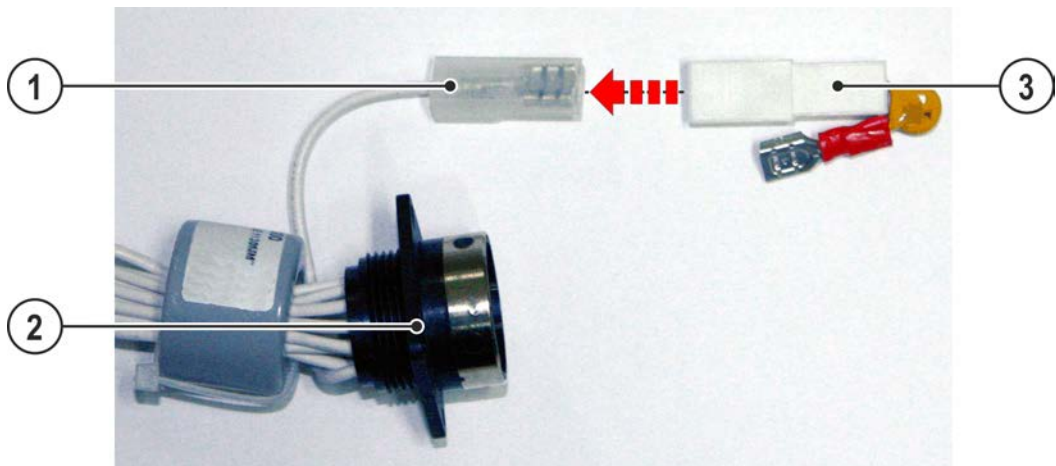

Figure 3-4

Item	Quantity	Description	Item number
1	1	Protective sleeve	
2	1	19-pole interface for automated welding	094-009343-00000
3	1	Capacitor	092-000324-00012

- Connect the capacitor with the protective sleeve.

3.4 Assembly

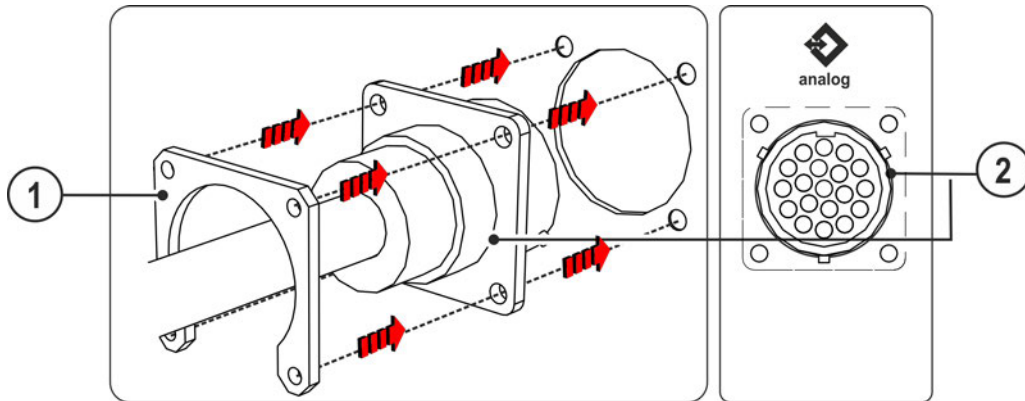

Figure 3-5

Item	Quantity	Description	Item number
1	1	Fixing plate	094-009379-00000
2	1	19-pole interface for automated welding	094-009343-00000

- Remove blind plug from the rear wall of the casing (see installation position).
- Insert the 19-pole interface for automated welding from the inside into the casing opening.
- Connect fixing plate from the inside onto the connection socket (panel opening downwards).

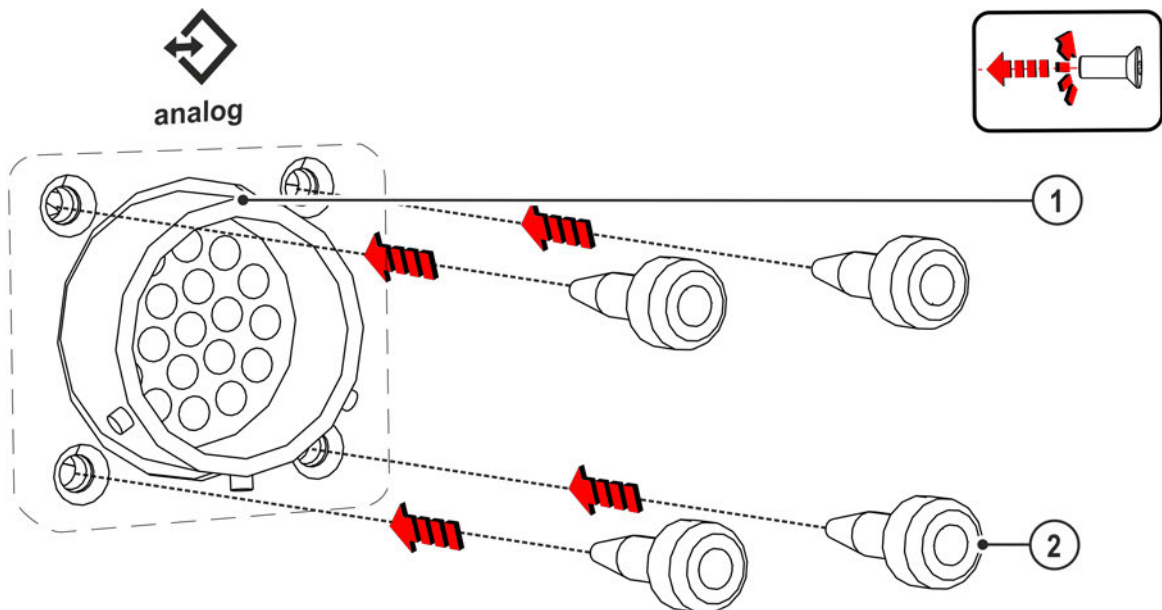

Figure 3-6

Item	Quantity	Description	Item number
1	1	19-pole interface for automated welding	094-009343-00000
2	4	Torx screw M3x10	094-023445-00000

- From outside, screw the torx screw into the cable harness connection socket.
- Attach protective earth (X3 – 1) to housing.

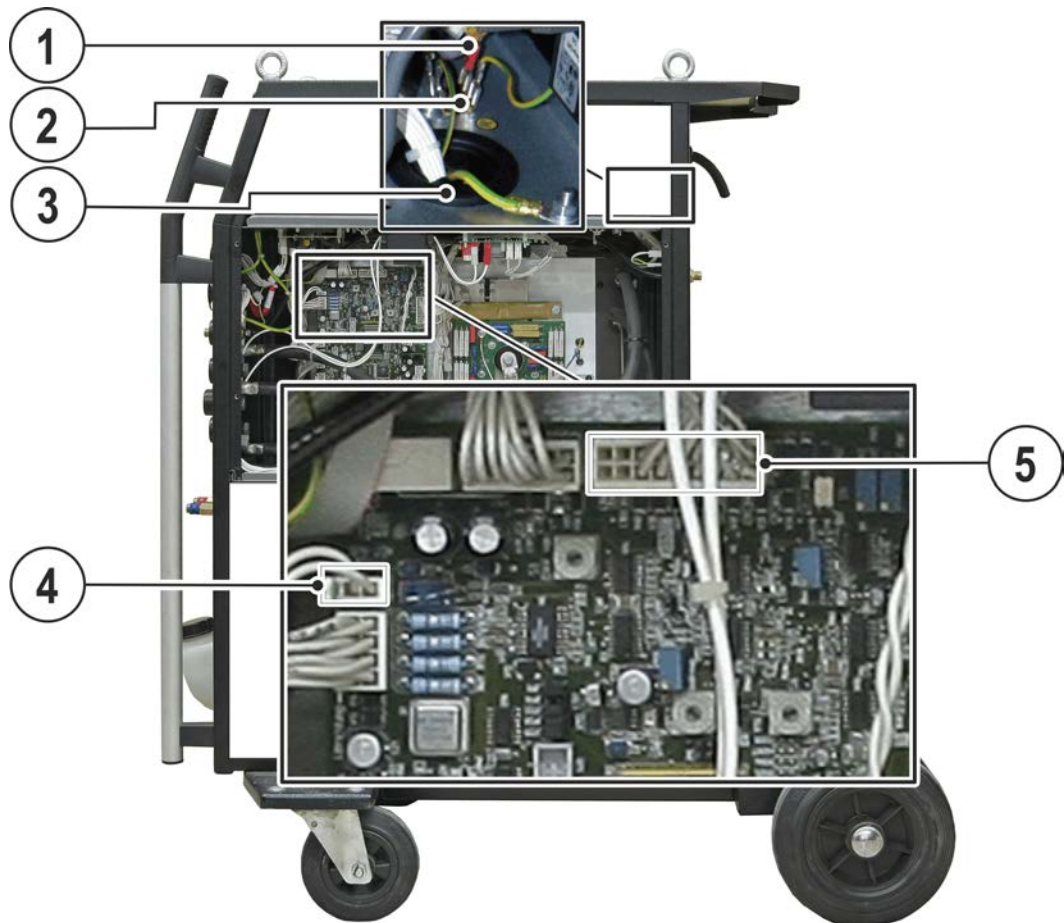

Figure 3-7

Item	Symbol	Description
1		Capacitor
2		Earth cable connecting nipple Connection of green-yellow earth cable from the intermediate tube package
3		Cable bushing Opening through a wall for laying cables or hoses
4		PCB T320, connection X6 (2-pole)
5		PCB T320, connection X5 (18-pole)

- Fit connector plug on the capacitor onto the earthing point.
- Connect cable harness through the cable bushing into the intermediate panel.
- Connect 18-pole connector plug cable harness onto PCB T320, connection X5.
- Connect 2-pole connector plug cable harness onto PCB T320, connection X6.
- Plug in the earth cable.
- Screw on the casing cover.

3.5 Final inspection

3.5.1 General

WARNING



Protective earth PE!

To protect persons and animals against dangerous live voltages and electric shocks in the event of a fault, the casing panels on the unit are connected to a green/yellow protective earth.

- After conversion, re-connect the protective earth to the casing panels!



Danger due to failure to carry out the final inspection!

After installation or conversion, all mechanical and electrical connections must be checked for correct installation to avoid any potential injuries.

- No leads or tubes should be squashed or laid on sharp edges.
- Check all mechanical connections to ensure that they are fitted correctly!
- Carry out the final inspection!
- Carry out the functional test!



Dangers resulting from failure to perform test after conversion!

Before reconnection, “Inspection and Testing during Operation” according to IEC/BS EN 60974-4 “Arc welding systems – Inspection and Testing during Operation” has to be performed!

- Perform test to IEC / DIN EN 60974-4!

Keep the conversion instructions with the machine documentation!

When ordering spare parts, ensure that the item number and serial number of the machine are quoted!