



**EN**

**Transport systems**

**Trolley 54**

099-008639-EW501

Observe additional system documents!

28.04.2022

**Register now  
and benefit!  
Jetzt Registrieren  
und Profitieren!**

[www.ewm-group.com](http://www.ewm-group.com)



# General instructions

## WARNING



### **Read the operating instructions!**

#### **The operating instructions provide an introduction to the safe use of the products.**

- Read and observe the operating instructions for all system components, especially the safety instructions and warning notices!
- Observe the accident prevention regulations and any regional regulations!
- The operating instructions must be kept at the location where the machine is operated.
- Safety and warning labels on the machine indicate any possible risks. Keep these labels clean and legible at all times.
- The machine has been constructed to state-of-the-art standards in line with any applicable regulations and industrial standards. Only trained personnel may operate, service and repair the machine.
- Technical changes due to further development in machine technology may lead to a differing welding behaviour.

**In the event of queries on installation, commissioning, operation or special conditions at the installation site, or on usage, please contact your sales partner or our customer service department on +49 2680 181-0.**

**A list of authorised sales partners can be found at [www.ewm-group.com/en/specialist-dealers](http://www.ewm-group.com/en/specialist-dealers).**

Liability relating to the operation of this equipment is restricted solely to the function of the equipment. No other form of liability, regardless of type, shall be accepted. This exclusion of liability shall be deemed accepted by the user on commissioning the equipment.

The manufacturer is unable to monitor whether or not these instructions or the conditions and methods are observed during installation, operation, usage and maintenance of the equipment.

An incorrectly performed installation can result in material damage and injure persons as a result. For this reason, we do not accept any responsibility or liability for losses, damages or costs arising from incorrect installation, improper operation or incorrect usage and maintenance or any actions connected to this in any way.

### © EWM AG

Dr. Günter-Henle-Strasse 8  
56271 Mündersbach Germany  
Tel.: +49 2680 181-0, Fax: -244  
Email: [info@ewm-group.com](mailto:info@ewm-group.com)  
**[www.ewm-group.com](http://www.ewm-group.com)**

The copyright to this document remains the property of the manufacturer.

Copying, including extracts, only permitted with written approval.

The content of this document has been prepared and reviewed with all reasonable care. The information provided is subject to change; errors excepted.

### **Data security**

The user is responsible for backing up data of all changes from the factory setting. The user is liable for erased personal settings. The manufacturer does not assume any liability for this.

<b>1</b>	<b>Contents</b>	<b>3</b>
<b>1</b>	<b>Contents</b>	<b>3</b>
<b>2</b>	<b>For your safety</b>	<b>4</b>
2.1	Notes on using these operating instructions	4
2.2	Explanation of icons	5
2.3	Safety instructions	6
2.4	Transport and installation	9
<b>3</b>	<b>Intended use</b>	<b>11</b>
3.1	Applications	11
3.2	Use and operation solely with the following machines	11
3.3	Documents which also apply	11
3.3.1	Warranty	11
3.3.2	Service documents (spare parts)	12
3.3.3	Part of the complete documentation	12
<b>4</b>	<b>Machine description – quick overview</b>	<b>13</b>
4.1	Front view / side view from left	13
<b>5</b>	<b>Design and function</b>	<b>15</b>
5.1	System overview	15
5.1.1	Mounting with assembly set	15
5.1.2	Mounting with assembly set and cross arm	17
5.2	Assembly	19
5.2.1	Parts list	19
5.2.2	Assembling the transport cart	20
5.2.3	Final assembly	21
5.3	Mounting the machine	21
5.4	Transport and installation	21
<b>6</b>	<b>Maintenance, care and disposal</b>	<b>23</b>
6.1	Maintenance work, intervals	23
6.1.1	Daily maintenance tasks	23
6.1.2	Monthly maintenance tasks	23
6.2	Disposing of equipment	23
<b>7</b>	<b>Technical data</b>	<b>24</b>
7.1	Trolley 54	24
<b>8</b>	<b>Accessories</b>	<b>25</b>
8.1	General accessories	25
<b>9</b>	<b>Appendix</b>	<b>26</b>
9.1	Searching for a dealer	26

## 2 For your safety

### 2.1 Notes on using these operating instructions

#### **DANGER**

**Working or operating procedures which must be closely observed to prevent imminent serious and even fatal injuries.**

- Safety notes include the "DANGER" keyword in the heading with a general warning symbol.
- The hazard is also highlighted using a symbol on the edge of the page.

#### **WARNING**

**Working or operating procedures which must be closely observed to prevent serious and even fatal injuries.**

- Safety notes include the "WARNING" keyword in the heading with a general warning symbol.
- The hazard is also highlighted using a symbol in the page margin.

#### **CAUTION**

**Working or operating procedures which must be closely observed to prevent possible minor personal injury.**

- The safety information includes the "CAUTION" keyword in its heading with a general warning symbol.
- The risk is explained using a symbol on the edge of the page.



**Technical aspects which the user must observe to avoid material or equipment damage.**

Instructions and lists detailing step-by-step actions for given situations can be recognised via bullet points, e.g.:

- Insert the welding current lead socket into the relevant socket and lock.

## 2.2 Explanation of icons

Symbol	Description	Symbol	Description
	Indicates technical aspects which the user must observe.		Activate and release / Tap / Tip
	Switch off machine		Release
	Switch on machine		Press and hold
			Switch
	Incorrect / Invalid		Turn
	Correct / Valid		Numerical value – adjustable
	Input		Signal light lights up in green
	Navigation		Signal light flashes green
	Output		Signal light lights up in red
	Time representation (e.g.: wait 4 s / actuate)		Signal light flashes red
	Interruption in the menu display (other setting options possible)		
	Tool not required/do not use		
	Tool required/use		

## 2.3 Safety instructions

### **WARNING**



**Risk of accidents due to non-compliance with the safety instructions!**

**Non-compliance with the safety instructions can be fatal!**

- Carefully read the safety instructions in this manual!
- Observe the accident prevention regulations and any regional regulations!
- Inform persons in the working area that they must comply with the regulations!



**Risk of injury from electrical voltage!**

**Voltages can cause potentially fatal electric shocks and burns on contact. Even low voltages can cause a shock and lead to accidents.**

- Never touch live components such as welding current sockets or stick, tungsten or wire electrodes!
- Always place torches and electrode holders on an insulated surface!
- Wear the full personal protective equipment (depending on the application)!
- The machine may only be opened by qualified personnel!
- The device must not be used to defrost pipes!

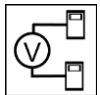

**Hazard when interconnecting multiple power sources!**

**If a number of power sources are to be connected in parallel or in series, only a technical specialist may interconnect the sources as per standard IEC 60974-9:2010: Installation and use and German Accident Prevention Regulation BVG D1 (formerly VBG 15) or country-specific regulations.**

**Before commencing arc welding, a test must verify that the equipment cannot exceed the maximum permitted open circuit voltage.**

- Only qualified personnel may connect the machine.
- When taking individual power sources out of operation, all mains and welding current leads must be safely disconnected from the welding system as a whole. (Hazard due to reverse polarity voltage!)
- Do not interconnect welding machines with pole reversing switch (PWS series) or machines for AC welding since a minor error in operation can cause the welding voltages to be combined, which is not permitted.



**Risk of injury due to radiation or heat!**

**Arc radiation can lead to skin and eye injuries.**

**Contact with hot workpieces and sparks can lead to burns.**

- Use hand shield or welding helmet with the appropriate safety level (depends on the application).
- Wear dry protective clothing (e.g. hand shield, gloves, etc.) in accordance with the applicable regulations of your country.
- Persons who are not directly involved should be protected with a welding curtain or suitable safety screen against radiation and the risk of blinding!

**⚠ WARNING****Risk of injury due to improper clothing!**

**During arc welding, radiation, heat and voltage are sources of risk that cannot be avoided. The user has to be equipped with the complete personal protective equipment at all times. The protective equipment has to include:**

- Respiratory protection against hazardous substances and mixtures (fumes and vapours); otherwise implement suitable measures such as extraction facilities.
- Welding helmet with proper protection against ionizing radiation (IR and UV radiation) and heat.
- Dry welding clothing (shoes, gloves and body protection) to protect against warm environments with conditions comparable to ambient temperatures of 100 °C or higher and arcing and work on live components.
- Hearing protection against harming noise.

**Explosion risk!**

**Apparently harmless substances in closed containers may generate excessive pressure when heated.**

- Move containers with inflammable or explosive liquids away from the working area!
- Never heat explosive liquids, dusts or gases by welding or cutting!

**Fire hazard!**

**Due to the high temperatures, sparks, glowing parts and hot slag that occur during welding, there is a risk of flames.**

- Be watchful of potential sources of fire in the working area!
- Do not carry any easily inflammable objects, e.g. matches or lighters.
- Ensure suitable fire extinguishers are available in the working area!
- Thoroughly remove any residue of flammable materials from the workpiece prior to starting to weld.
- Only further process workpieces after they have cooled down. Do not allow them to contact any flammable materials!

## ⚠ CAUTION



### Smoke and gases!

**Smoke and gases can lead to breathing difficulties and poisoning. In addition, solvent vapour (chlorinated hydrocarbon) may be converted into poisonous phosgene due to the ultraviolet radiation of the arc!**

- Ensure that there is sufficient fresh air!
- Keep solvent vapour away from the arc beam field!
- Wear suitable breathing apparatus if appropriate!



### Noise exposure!

**Noise exceeding 70 dBA can cause permanent hearing damage!**

- Wear suitable ear protection!
- Persons located within the working area must wear suitable ear protection!



**According to IEC 60974-10, welding machines are divided into two classes of electromagnetic compatibility (the EMC class can be found in the Technical data) > see 7 chapter:**



**Class A** machines are not intended for use in residential areas where the power supply comes from the low-voltage public mains network. When ensuring the electromagnetic compatibility of class A machines, difficulties can arise in these areas due to interference not only in the supply lines but also in the form of radiated interference.



**Class B** machines fulfil the EMC requirements in industrial as well as residential areas, including residential areas connected to the low-voltage public mains network.

### Setting up and operating

When operating arc welding systems, in some cases, electro-magnetic interference can occur although all of the welding machines comply with the emission limits specified in the standard. The user is responsible for any interference caused by welding.

In order to **evaluate** any possible problems with electromagnetic compatibility in the surrounding area, the user must consider the following: (see also EN 60974-10 Appendix A)

- Mains, control, signal and telecommunication lines
- Radios and televisions
- Computers and other control systems
- Safety equipment
- The health of neighbouring persons, especially if they have a pacemaker or wear a hearing aid
- Calibration and measuring equipment
- The immunity to interference of other equipment in the surrounding area
- The time of day at which the welding work must be carried out

### Recommendations for reducing interference emission

- Mains connection, e.g. additional mains filter or shielding with a metal tube
- Maintenance of the arc welding system
- Welding leads should be as short as possible and run closely together along the ground
- Potential equalization
- Earthing of the workpiece. In cases where it is not possible to earth the workpiece directly, it should be connected by means of suitable capacitors.
- Shielding from other equipment in the surrounding area or the entire welding system



### Electromagnetic fields!

**The power source may cause electrical or electromagnetic fields to be produced which could affect the correct functioning of electronic equipment such as IT or CNC devices, telecommunication lines, power cables, signal lines and pacemakers.**



- Observe the maintenance instructions > see 6.1 chapter!
- Unwind welding leads completely!
- Shield devices or equipment sensitive to radiation accordingly!
- The correct functioning of pacemakers may be affected (obtain advice from a doctor if necessary).



**⚠ CAUTION****Obligations of the operator!**

**The respective national directives and laws must be complied with when operating the machine!**

- Implementation of national legislation relating to framework directive 89/391/EEC on the introduction of measures to encourage improvements in the safety and health of workers at work and associated individual guidelines.
- In particular, directive 89/655/EEC concerning the minimum safety and health requirements for the use of work equipment by workers at work.
- The regulations applicable to occupational safety and accident prevention in the country concerned.
- Setting up and operating the machine as per IEC 60974.-9.
- Brief the user on safety-conscious work practices on a regular basis.
- Regularly inspect the machine as per IEC 60974.-4.



**The manufacturer's warranty becomes void if non-genuine parts are used!**

- **Only use system components and options (power sources, welding torches, electrode holders, remote controls, spare parts and replacement parts, etc.) from our range of products!**
- **Only insert and lock accessory components into the relevant connection socket when the machine is switched off.**

**Requirements for connection to the public mains network**

High-performance machines can influence the mains quality by taking current from the mains network. For some types of machines, connection restrictions or requirements relating to the maximum possible line impedance or the necessary minimum supply capacity at the interface with the public network (Point of Common Coupling, PCC) can therefore apply. In this respect, attention is also drawn to the machines' technical data. In this case, it is the responsibility of the operator, where necessary in consultation with the mains network operator, to ensure that the machine can be connected.

## 2.4 Transport and installation

**⚠ WARNING****Risk of injury due to improper handling of shielding gas cylinders!**

**Improper handling and insufficient securing of shielding gas cylinders can cause serious injuries!**

- Observe the instructions from the gas manufacturer and any relevant regulations concerning the use of compressed air!
- Do not attach any element to the shielding gas cylinder valve!
- Prevent the shielding gas cylinder from heating up.

## CAUTION



### **Risk of accidents due to supply lines!**

**During transport, attached supply lines (mains leads, control cables, etc.) can cause risks, e.g. by causing connected machines to tip over and injure persons!**

- Disconnect all supply lines before transport!



### **Risk of tipping!**

**There is a risk of the machine tipping over and injuring persons or being damaged itself during movement and set up. Tilt resistance is guaranteed up to an angle of 10° (according to IEC 60974-1).**

- Set up and transport the machine on level, solid ground.
- Secure add-on parts using suitable equipment.



### **Risk of accidents due to incorrectly installed leads!**

**Incorrectly installed leads (mains, control and welding leads or intermediate hose packages ) can present a tripping hazard.**

- Lay the supply lines flat on the floor (avoid loops).
- Avoid laying the leads on passage ways.



### **Risk of injury from heated coolant and its connections!**

**The coolant used and its connection or connection points can heat up significantly during operation (water-cooled version). When opening the coolant circuit, escaping coolant may cause scalding.**

- Open the coolant circuit only when the power source or cooling unit is switched off!
- Wear proper protective equipment (protective gloves)!
- Seal open connections of the hose leads with suitable plugs.



***The units are designed for operation in an upright position!***

***Operation in non-permissible positions can cause equipment damage.***

- ***Only transport and operate in an upright position!***



***Accessory components and the power source itself can be damaged by incorrect connection!***

- ***Only insert and lock accessory components into the relevant connection socket when the machine is switched off.***
- ***Comprehensive descriptions can be found in the operating instructions for the relevant accessory components.***
- ***Accessory components are detected automatically after the power source is switched on.***



***Protective dust caps protect the connection sockets and therefore the machine against dirt and damage.***

- ***The protective dust cap must be fitted if there is no accessory component being operated on that connection.***
- ***The cap must be replaced if faulty or if lost!***

### 3 Intended use

#### WARNING



##### Hazards due to improper usage!

The machine has been constructed to the state of the art and any regulations and standards applicable for use in industry and trade. It may only be used for the welding procedures indicated at the rating plate. Hazards may arise for persons, animals and material objects if the equipment is not used correctly. No liability is accepted for any damages arising from improper usage!

- The equipment must only be used in line with its designated purpose and by trained or expert personnel!
- Do not improperly modify or convert the equipment!

### 3.1 Applications

For transporting arc welding systems and process-dependent components such as torch cooling modules or shielding gas cylinders.

### 3.2 Use and operation solely with the following machines

The following system components can be combined:

<b>Power source</b>	Drive XQ - D.0001 Drive XQ AC - D.0001 Pico drive 200C - D.0009 Pico drive 4L - D.0011 Taurus drive 4L Basic - D.0011 Pico 350 cel - TG.0001 Taurus 400 Basic TDG - TG.0001 Tetrix 230 DC - TG.0002 Tetrix 230 AC/DC - TG.0002 Tetrix 300-2 TM - TG.0002 Tetrix 300 AC/DC TM - TG.0002 Tetrix 300 TM - TG.0002 Picomig 225 TKG - TG.0003 Picomig 355 TKM - TG.0003 Phoenix XQ 355 - 505 - TG.0004 Taurus XQ 355 - 505 - TG.0004 Tetrix XQ 230 DC - TG.0011 Tetrix XQ 230 AC/DC - TG.0011
<b>Cooling unit</b>	Cool 50-2U40 - K.0002 Cool 50-2U42 - K.0002 Cool XQ 40- K.0006 Cool XQ 40 MV - K.0006
<b>Transport vehicle</b>	Trolley 54
<b>Assembly set for mounting on the transport cart (required)</b>	ON TR Trolley 54 ON TG.01 MS TR.20/21 - TG.0001 ON TG.02 MS TR.20/21 - TG.0002 ON TG.11 MS TR.20/21 - TG.0011 ON TG.03/04 MS TR.20/21 - TG.0003 / TG.0004

### 3.3 Documents which also apply

#### 3.3.1 Warranty

For information on warranty, maintenance and testing, see the website [www.ewm-group.com](http://www.ewm-group.com).

### 3.3.2 Service documents (spare parts)

⚠ WARNING

**No improper repairs and modifications!**  
**To prevent injuries and damage to the machine, only competent personnel (authorised service personnel) are allowed to repair or modify the machine.**  
**Unauthorised manipulations will invalidate the warranty!**

- Instruct competent personnel (authorised service personnel) to repair the machine.

Spare parts can be obtained from the relevant authorised dealer.

### 3.3.3 Part of the complete documentation

**This document is part of the complete documentation and valid only in combination with all other parts of these instructions! Read and observe the operating instructions for all system components, especially the safety instructions!**

The illustration shows a general example of a welding system.

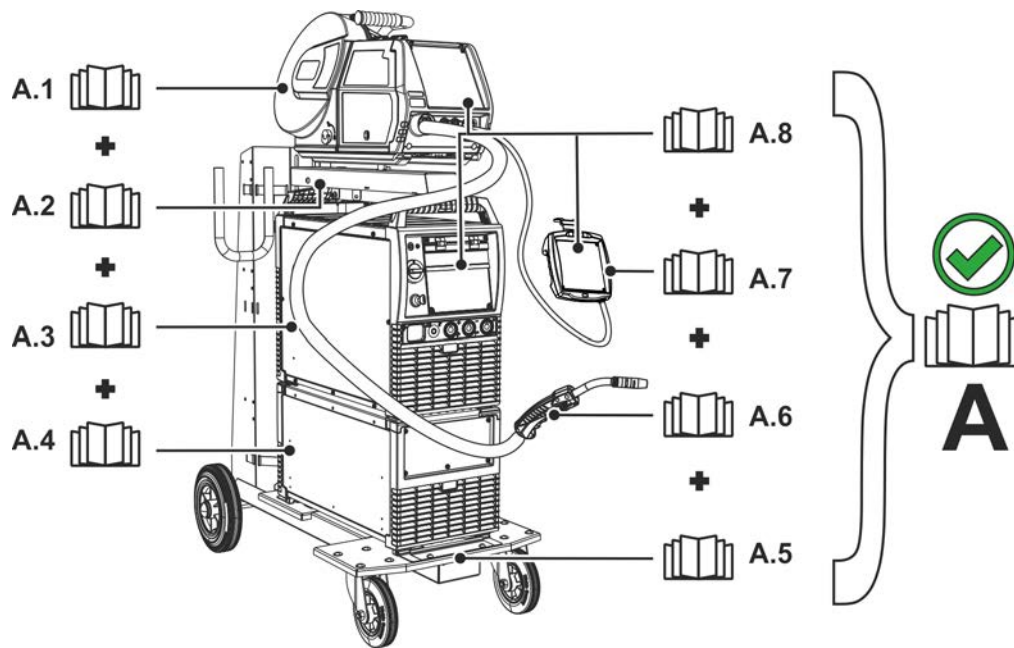

Figure 3-1

Item	Documentation
A.1	Wire feeder
A.2	Conversion instructions
A.3	Power source
A.4	Cooling unit, voltage converter, tool box etc.
A.5	Trolley
A.6	Welding torch
A.7	Remote control
A.8	Control
A	Complete documentation

**4 Machine description – quick overview**

**4.1 Front view / side view from left**

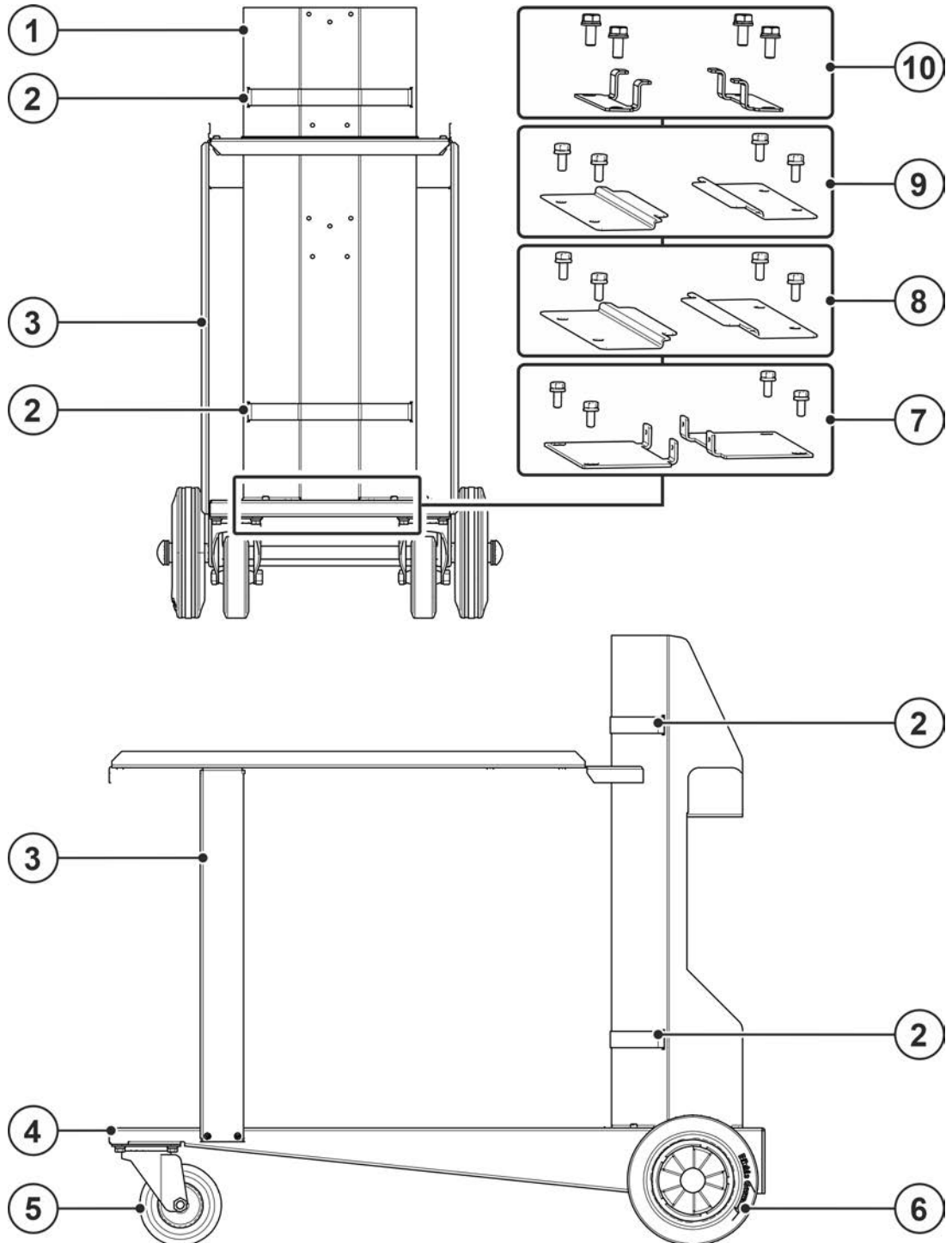

Figure 4-1

# Machine description – quick overview

Front view / side view from left



Item	Symbol	Description
1		<b>Shielding gas cylinder holder</b>
2		<b>Securing element</b> Clamping belt for attaching the shielding gas cylinder
3		<b>ON TR Trolley 54 &gt; see 8 chapter</b> Cross arm for holding a welding machine or wire feeder
4		<b>Machine carrier plate</b> To support the welding machine.
5		<b>Wheels, guide castors</b>
6		<b>Wheels, fixed castors</b>
7		<b>ON TG.11 MS TR.20/21 &gt; see 8 chapter</b> Assembly set for mounting on transport cart
8		<b>ON TG.03/04 MS TR.20/21 &gt; see 8 chapter</b> Assembly set for mounting on transport cart
9		<b>ON TG.02 MS TR.20/21 &gt; see 8 chapter</b> Assembly set for mounting on transport cart
10		<b>ON TG.01 MS TR.20/21 &gt; see 8 chapter</b> Assembly set for mounting on transport cart

**5 Design and function**

**5.1 System overview**

**5.1.1 Mounting with assembly set**

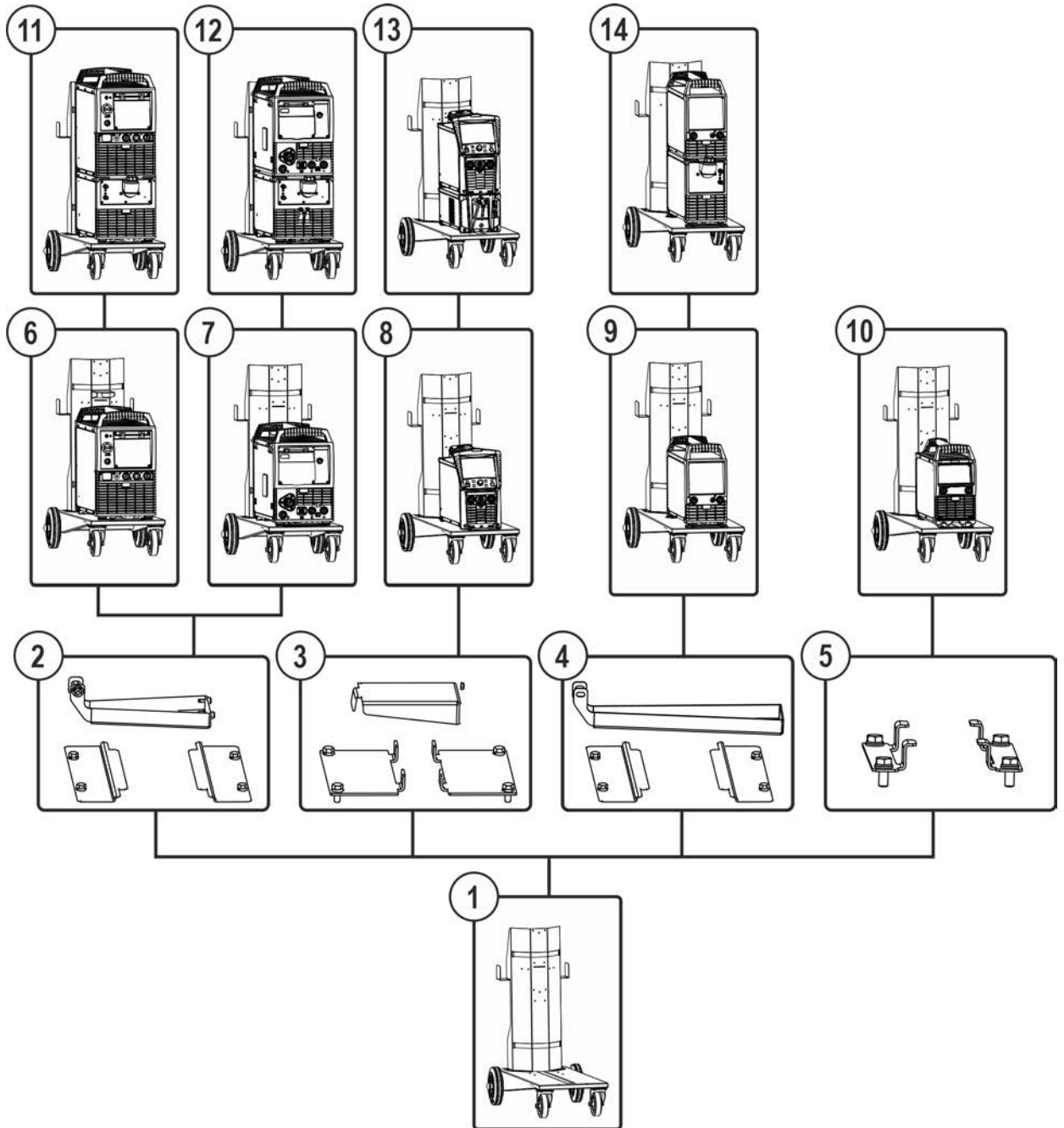

Figure 5-1

Item	Symbol	Description
1		Transport cart
2		<b>ON TG.03/04 MS TR.20/21 &gt; see 8 chapter</b> Assembly set for mounting on transport cart - 092-004392-00000
3		<b>ON TG.11 MS TR.20/21 &gt; see 8 chapter</b> Assembly set for mounting on transport cart - 092-004391-00000
4		<b>ON TG.02 MS TR.20/21 &gt; see 8 chapter</b> Assembly set for mounting on transport cart - 092-004418-00000
5		<b>ON TG.01 MS TR.20/21 &gt; see 8 chapter</b> Assembly set for mounting on transport cart - 092-004395-00000
6		Transport cart + TG.0004
7		Transport cart + TG.0003
8		Transport cart + TG.0011
9		Transport cart + TG.0002
10		Transport cart + TG.0001
11		Transport cart + TG.0004 + K.0002
12		Transport cart + TG.0003 + K.0002
13		Transport cart + TG.0011 + K.0006
14		Transport cart + TG.0002 + K.0001



**5.1.2 Mounting with assembly set and cross arm**

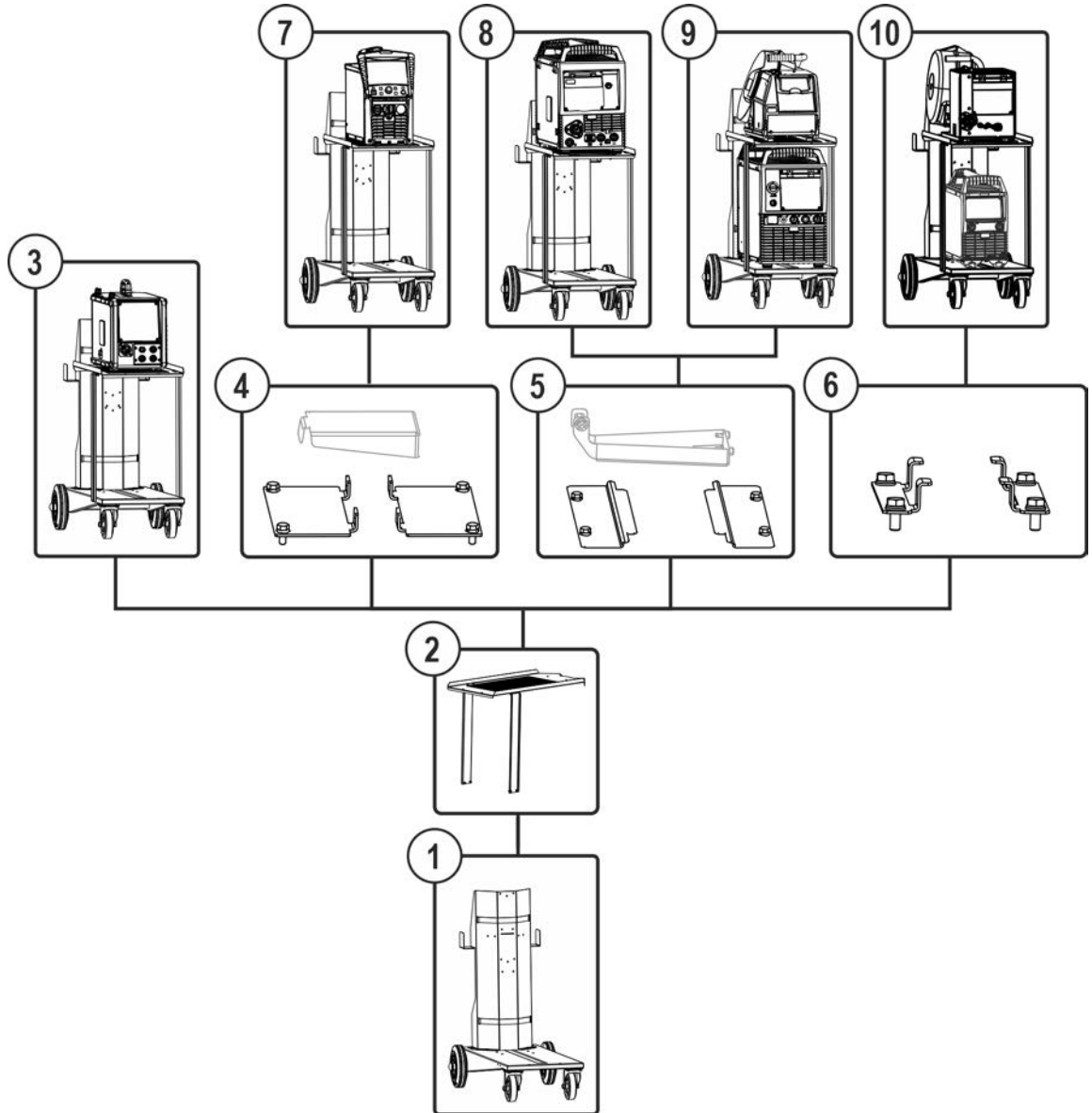

Figure 5-2

Item	Symbol	Description
1		Transport cart
2		<b>ON TA TR.21 &gt; see 8 chapter</b> Cross arm for holding a welding machine or wire feeder - 092-004390-00000
3		<b>Transport cart + T.0005</b>
4		<b>ON TG.11 MS TR.20/21 &gt; see 8 chapter</b> Assembly set for mounting on transport cart - 092-004391-00000
5		<b>ON TG.03/04 MS TR.20/21 &gt; see 8 chapter</b> Assembly set for mounting on transport cart - 092-004392-00000
6		<b>ON TG.01 MS TR.20/21 &gt; see 8 chapter</b> Assembly set for mounting on transport cart - 092-004395-00000
7		<b>Transport cart + TG.0011</b>
8		<b>Transport cart + TG.0003</b>
9		<b>Transport cart + TG.0004 + D.0001</b>
10		<b>Transport cart + TG.0001 + D.0011</b>

## 5.2 Assembly

### 5.2.1 Parts list

Before conversion, check that the retrofit kit is complete (see parts list).

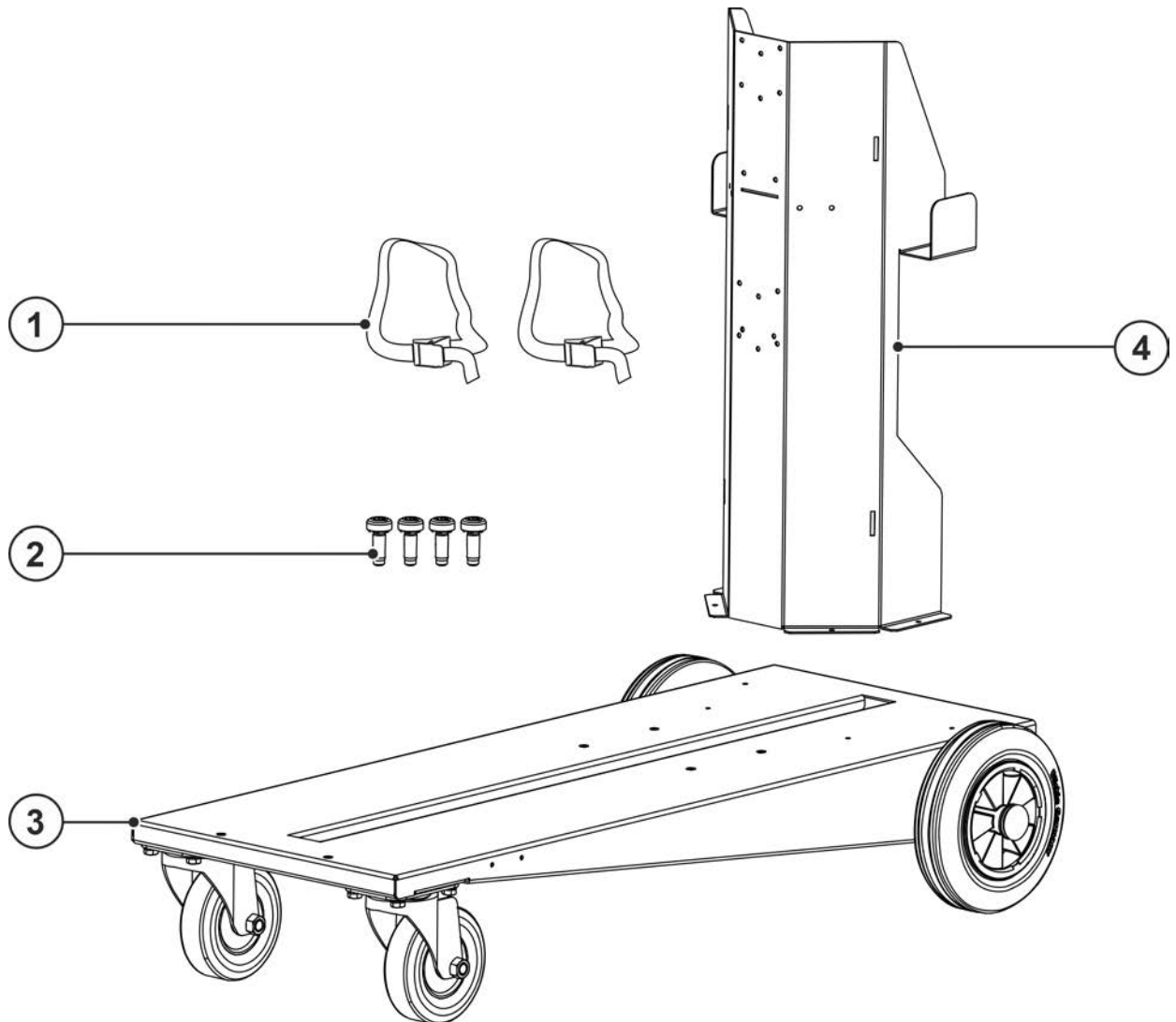

Figure 5-3

Item	Quantity	Description	Item number
1	2	Tension belt with clamping lock	094-011806-00000
2	4	Threaded grooved pin M5 x 14	094-023235-00001
3	1	Unit carrier plate	
4	1	Holder for shielding gas cylinder	

## 5.2.2 Assembling the transport cart

**⚠ WARNING**

**Improper work carried out!**  
**In the event of improper work carried out on the display stand, the display stand may lose stability, tip over and result in serious injury!**

- Only use the construction and fitting parts supplied!
- Do not load the display stand without reinforcement panels affixed!

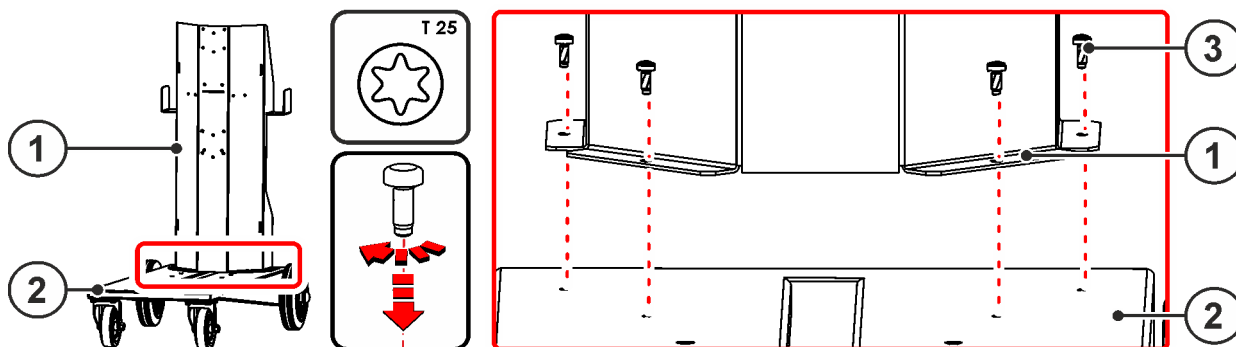

Figure 5-4

Item	Quantity	Description	Item number
1	1	Holder for shielding gas cylinder	
2	1	Unit carrier plate	
3	4	Threaded grooved pin M5 x 14	094-023235-00001

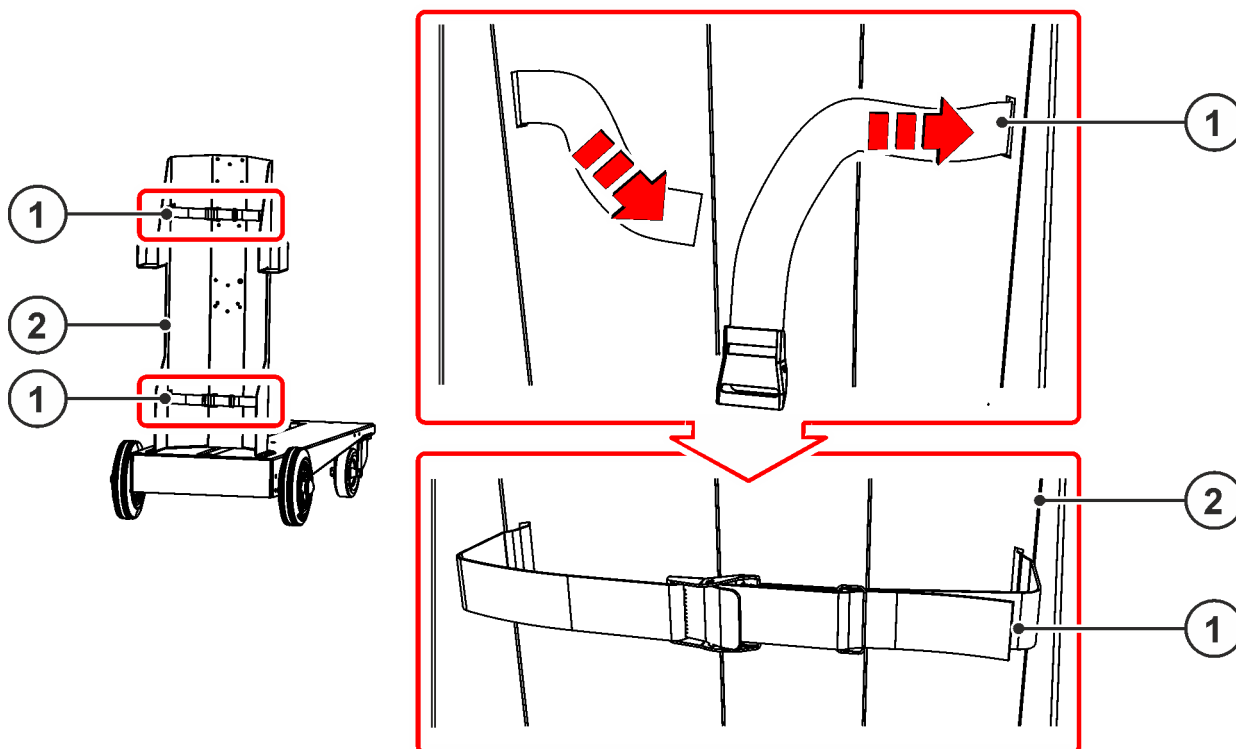

Figure 5-5

Item	Quantity	Description	Item number
1	2	Tension belt with clamping lock	094-011806-00000
2	1	Holder for shielding gas cylinder	

### 5.2.3 Final assembly

#### ⚠ WARNING



**Danger due to failure to carry out the final inspection!**  
**Parts that are incorrectly fitted or that become loose are a source of danger.**

- Check all mechanical connections to ensure that they are fitted correctly!
- Carry out the final inspection!
- Carry out the functional test!

### 5.3 Mounting the machine

#### ⚠ CAUTION



**Improperly fastened machines!**

**Machines, machine combinations and accessories that are not properly fastened to transport systems may tip over during transport and cause injury.**

- Use the systems only for transporting the machines specified in > see 3.2 chapter.
- Secure the machines in the middle or at the specified attachment points on the machine carrier.
- To fasten the machines, use only the original accessories supplied or specified by the manufacturer > see 8 chapter!
- Check the attachment points before each transport and at regular intervals.

This transport system is designed to accommodate modular device systems. By attaching additional options, up to two system components (e.g., power source and cooling module or an identical module > see 5.1 chapter) can be mounted on the transport cart (see the relevant conversion instructions).

### 5.4 Transport and installation

#### ⚠ WARNING



**Risk of accident due to improper transport of machines that must not be lifted!**

**Do not lift or suspend the machine! The machine can drop and cause injuries! The handles, straps or brackets are suitable for transport by hand only!**

- The machine must not be suspended or lifted using a crane.

#### ⚠ CAUTION



**Risk of accident from improperly attached machines!**

**Depending on the machine series, the transport cart for fastening the machines must be adapted. If the transport cart is not adapted, the transported machine may tip over and injure people!**

- After a modification and before each transport, check that all fastenings are secure!

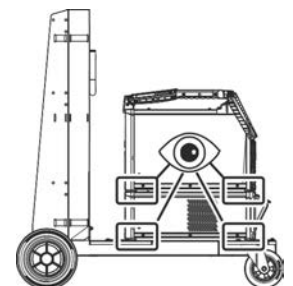

## ⚠ CAUTION



**Risk of accidents due to supply lines!**

**During transport, attached supply lines (mains leads, control cables, etc.) can cause risks, e.g. by causing connected machines to tip over and injure persons!**

- Disconnect all supply lines before transport!



Figure 5-6

## 6 Maintenance, care and disposal

Repair and maintenance work may only be performed by qualified authorised personnel; otherwise the right to claim under warranty is void. In all service matters, always consult the dealer who supplied the machine. Return deliveries of defective equipment subject to warranty may only be made through your dealer. When replacing parts, use only original spare parts. When ordering spare parts, please quote the machine type, serial number and item number of the machine, as well as the type designation and item number of the spare part.

Under the specified ambient conditions and normal working conditions this machine is essentially maintenance-free and requires just a minimum of care.

Contamination of the machine may impair service life and duty cycle. The cleaning intervals depend on the ambient conditions and the resulting contamination of the machine. The minimum interval is every six months.

### 6.1 Maintenance work, intervals

#### 6.1.1 Daily maintenance tasks

- Gas cylinder securing elements
- Other, general condition
- Keep moving parts clean.
- Wheels and their securing elements
- Transport elements (strap, lifting lugs, handle)

#### 6.1.2 Monthly maintenance tasks

- Tighten the screw connections.
- Check bearings for damage.
- Service at regular intervals and check for errors.
- Clean surfaces and glass with a damp cloth (do not use aggressive cleaning agents)!

### 6.2 Disposing of equipment



**Proper disposal!**

**The machine contains valuable raw materials that should be recycled.**

- **Do not dispose of these materials using household waste!**
- **Follow the official regulations for disposal!**

## 7 Technical data

### 7.1 Trolley 54

**Performance specifications and guarantee only in connection with original spare and replacement parts!**

max. Height (Shielding gas cylinder)	1660 mm 65.35 inch
max. Diameter (Shielding gas cylinder)	229 mm 9 inch
Filling quantity (Shielding gas cylinder)	10 l - 33 l 2.6 gal. - 8.7 gal.
max. Filling pressure (Shielding gas cylinder)	200 bar 20 MPa
Dimensions (l x b x h)	1001 x 527 x 932 mm 39.4 x 21.1 x 36.7 inch
Weight	21,2 kg 47.0 lb.



## 8 Accessories

Performance-dependent accessories like torches, workpiece leads, electrode holders or intermediate hose packages are available from your authorised dealer.

### 8.1 General accessories

Type	Designation	Item no.
ON TR Trolley 54	Cross arm for holding a welding machine or wire feeder	092-004390-00000
ON TG.11 MS TR.20/21	Assembly set for mounting on transport cart	092-004391-00000
ON TG.03/04 MS TR.20/21	Assembly set for mounting on transport cart	092-004392-00000
ON TG.01 MS TR.20/21	Assembly set for mounting on transport cart	092-004395-00000
ON TG.02 MS TR.20/21	Assembly set for mounting on transport cart	092-004418-00000

## 9 Appendix

### 9.1 Searching for a dealer

Sales & service partners

[www.ewm-group.com/en/specialist-dealers](http://www.ewm-group.com/en/specialist-dealers)



"More than 400 EWM sales partners worldwide"